



City of Port Colborne
Regular Meeting of Committee of the Whole 17-19
Monday, June 10, 2019 – 6:30 p.m.
Council Chambers, 3rd Floor, 66 Charlotte Street

Addendum

Additional Item(s) for Consideration:

Notes	Item	Description / Recommendation	Page
WCS MB EB	18	<p><u>Engineering and Operations Department, Engineering Division, Report 2019-81, Subject Schihl Municipal Drains</u></p> <p>That Engineering and Operations Department, Engineering Division Report 2019-81 with respect to the Schihl Municipal Drain, be received for information.</p> <p>That staff be directed to advance the Schihl Municipal Drain Engineer's Report to that of the Meeting to Consider, as per Section 41, Chapter D.17 of the <i>Drainage Act R.S.O. 1990</i>.</p>	3
RB GB FD			
AD DK HW			

This page intentionally left blank



**Engineering and Operations Department
Engineering Division**

Report Number: 2019-81

Date: June 10, 2019

SUBJECT: Schihl Municipal Drains

1. PURPOSE:

This report, prepared by Alana Vander Veen, Drainage Superintendent, and authorized by Chris Lee, Director of Engineering and Operations, is being initiated in response to the final delivery of the Schihl Municipal Drain Engineer's Report, as prepared by Neal Morris, P. Eng of K. Smart Associates Limited. This drain is situated in the Town of Fort Erie (vicinity of Point Abino Road, Burger Road and Holloway Bay Road) and the City of Port Colborne (vicinity of Holloway Bay Road, Schihl Road and Forkes Road). The purpose of this report is to provide Council with an update on the Engineer's Report and requisite actions pertaining to the Meeting to Consider.

2) HISTORY, BACKGROUND, COUNCIL POLICY, PRACTICES

Further to Operational Services Division Director's Report (Engineering & Operations) Report No. 2017-178, which presented Council with the background and rationale leading up to the appointment of an engineer to prepare a new Engineer's Report for the Schihl Municipal Drain and the reappointment of a new Engineer within the firm, the following update is provided.

Current information/research indicates that the Schihl Drain dates back to 1909 when it was established as an Award Drain. A petition was presented to the municipality in 2002 to have the existing Award Drain recognized as a Municipal Drain, where it would then fall under the proceedings of the *Drainage Act R.S.O. 1990*.

In 2002, prior to their appointment of the Schihl Municipal Drain, K. Smart Associates Limited was appointed to prepare a new Engineer's report for the St. John's Marsh Municipal Drain which is the outlet for the Schihl Municipal Drain. Being the downstream drain, this drain took precedence and was completed in the spring of 2016. The St. John's Marsh Municipal Drain has undergone the bulk of the construction and is working towards completion which will provide for an adequate outlet of the Schihl Municipal Drain.

The final version of the Engineer's Report by K. Smart Associates Limited was delivered to the City of Port Colborne on March 28, 2019 and subsequently filed with the City Clerk on May 27, 2019.

3) STAFF COMMENTS AND DISCUSSIONS

With respect to the expanse of time to prepare the Section 4, *Drainage Act R.S.O. 1990* Engineer's Report for the Schihl Municipal Drain, there is very little to offer. The original

appointment took place under Drainage Superintendent René Landry with the subsequent appointment of Drainage Superintendent to Henri Benemeer in 2009. Mr. Benemeer prompted the Engineering Firm and a Public Information Session was held on November 29, 2017 by the Engineer of Record at the Port Colborne Operations Centre to see if the public still had an interest in continuing the finalization of the report. Those in attendance expressed a strong desire for continuation. A second meeting was held on January 15, 2019 which provided the residents with information on the *Drainage Act R.S.O. 1990* process, the watershed boundary, the proposed work and the landowner costs related to these works.

The new Engineer's Report as it currently stands, indicates a total estimated cost of \$392,980, for the construction of the Schihl Municipal Drain including the engineering, administration and HST (net). The total estimated cost of construction for the drain is \$327,550, with the balance of \$65,430 for engineering and administration.

4) OPTIONS AND FINANCIAL CONSIDERATIONS:

a) Do nothing.

This is not an option as the City is mandated by the Drainage Act to ensure that Municipal Drain Reports are kept up to date for future maintenance.

b) Other Options

An up to date Engineer's Report allows for drain maintenance and roadside ditching programs, which in turn allows staff to provide a reasonable level of service moving forward.

All administration and financing will be borne by the City of Port Colborne as the initiating municipality. Once the report is adopted and the construction is completed, the financing or cost of the project will be expensed to the Town of Fort Erie for their proportionate share, and to the City of Port Colborne property owners, according to the assessment schedule contained in the report. There will of course be some assessment to the general levy for City roads and properties within the watershed.

5) COMPLIANCE WITH STRATEGIC PLAN INITIATIVES

The Municipal Drain Maintenance Strategic Planning is currently in progress. This project is in compliance with all City legislative requirements.

6) ATTACHMENTS

- I. A Copy of the K. Smart Associates Limited, Schihl Municipal Drain Report, dated March 28, 2019.
- II. Aerial plan view of the St. John's Marsh Municipal Drain and Schihl Municipal Drain.

7) RECOMMENDATION

That Engineering and Operations Department, Engineering Division Report 2019-81 with respect to the Schihl Municipal Drain, be received for information.

That staff be directed to advance the Schihl Municipal Drain Engineer's Report to that of the Meeting to Consider, as per Section 41, Chapter D.17 of the *Drainage Act R.S.O. 1990*.

8) SIGNATURES

Prepared on June 10, 2019



Alana Vander Veen
Drainage Superintendent

Reviewed by:



Chris Lee
Director of Engineering & Operations

Reviewed and respectfully submitted by:



C. Scott Luey
Chief Administrative Officer

Reviewed by:



Brenda Garrett
Director of Corporate Services

ENGINEERING REPORT

For

SCHIHLE DRAIN

**Town of Fort Erie
and
City of Port Colborne**

(Geographic Townships of Bertie & Humberstone)

Region of Niagara

Date: March 28, 2019

File No. 02-210



K. SMART ASSOCIATES LIMITED

Kitchener

Sudbury

This page intentionally left blank

TABLE OF CONTENTS

1	EXECUTIVE SUMMARY	1
2	BACKGROUND	2
3	DRAINAGE HISTORY	2
4	INVESTIGATION	3
4.1	On-Site Meeting	3
4.2	Site Examination and Survey	4
4.3	Watershed Description	4
5	AUTHORITY FOR REPORT	4
6	DESIGN CONSIDERATIONS	5
6.1	Sufficient Outlet	5
6.2	Drain Capacity (Sizing)	5
6.3	Soil Conditions	5
7	MEETING(S)	5
7.1	Public Information Meetings	5
7.2	Other Meetings	9
8	ENVIRONMENTAL CONSIDERATIONS	9
8.1	Agency Notification	9
8.2	Agency Responses	9
9	RECOMMENDED WORK	10
9.1	Culverts	10
9.2	Changes to the Drain After the Bylaw is Passed	12
10	CONSTRUCTION CONSIDERATIONS	12
10.1	Utilities and Pre-Construction Approvals	12
10.2	Construction Scheduling	13
10.3	Minor Adjustments During Construction	13
10.4	Substantial Alterations to the Drain	13
10.5	Alignment of Drains	13
11	DRAWINGS AND SPECIFICATIONS	13
11.1	Drawings	13
11.2	Specifications	14
12	COST ESTIMATE	14
12.1	Allowances	14
12.2	Construction Cost Estimate	15
12.3	Engineering Cost Estimate	16
12.4	Estimate of Section 73 Costs	16
12.5	Harmonized Sales Tax	17
12.6	Estimated Cost Summary	17
13	ASSESSMENTS	19
13.1	Calculation of Assessments	19
13.2	Benefit Assessments (Section 22 and 24)	20
13.3	Outlet Liability Assessments (Section 23)	21
13.4	Increased Cost (Special) Assessments (Section 26)	21
13.5	Assessment Schedules	22
14	GRANT	23
15	PRIVACY OF LANDS	24
16	MAINTENANCE	24
16.1	General	24
16.2	Updating Future Maintenance Schedules	24
16.3	Culvert Maintenance	25
17	BYLAW	25

ATTACHMENTS

SCHEDULE A – SCHEDULE OF ASSESSMENTS

SCHEDULE B – SCHEDULE OF ASSESSMENTS FOR MAINTENANCE

SCHEDULE C – SCHEDULE FOR ACTUAL COST BYLAW

APPENDIX A – CALCULATION OF ASSESSMENTS FOR SCHEDULE A

APPENDIX B – CALCULATION OF ASSESSMENTS FOR FUTURE MAINTENANCE

SPECIFICATIONS

- Section 200 - General Conditions
- Section 300 - Special Provisions (See Drawing 11)

- Section 400 - Standard Specifications for Construction of Drains
 - Section 410 - Standard Specifications for Open Drains
- DRAWINGS 1 TO 12

Definitions:

- “Act” means The Drainage Act RSO 1990
- “CSP” means Corrugated Steel Pipe
- “Drain” means Schihl Drain
- “Grant” means grant paid under Agricultural Drainage Infrastructure Program
- “HDPE” means High Density Polyethylene
- “OMAFRA” means the Ontario Ministry of Agriculture, Food and Rural Affairs
- “Tribunal” means Agriculture, Food and Rural Affairs Appeal Tribunal

Table 9.1-1 - Summary of Culverts	10
Table 12.1-1 - Section 29 Allowance Rates	14
Table 12.1-2 - Section 30 Allowance Rates	15
Table 12.1-3 - Summary of Allowances	15
Table 12.6-1 – Estimated Cost Summary	15
Table 13.2-1 - Benefit Assessments	20
Table 13.3-1 - Runoff Factors Table	21
Table 13.4-1 – Estimated Special Assessments	22



K. SMART ASSOCIATES LIMITED

CONSULTING ENGINEERS AND PLANNERS

85 McIntyre Drive
Kitchener ON N2R 1H6

Tel: (519) 748-1199
Fax: (519) 748-6100
www.ksmart.ca

March 28, 2019

File No. 02-210

SCHIHL DRAIN TOWN OF FORT ERIE And CITY OF PORT COLBORNE

1 EXECUTIVE SUMMARY

This report is prepared pursuant to Section 4 of the Drainage Act RSO 1990 (the Act).

On October 28, 2002 the City of Port Colborne received a petition from several landowners in parts of Lots 2 & 3, Concessions 4 and 5 (Humberstone Twp) for improvements to the Schihl Award Drain. Pursuant to Section 8 of the Act, on November 6, 2002, May 26, 2003 and on November 27, 2017, K. Smart Associates Limited was appointed by resolutions of Council to prepare a report on the petition received on the Schihl Award Drain.

To address the petition received, this report recommends the following:

Excavation/Improvement of 3,541m of open drain

The estimated cost of this project is \$392,980.

The watershed served is approximately 299.5 hectares (740.1 acres).

Assessment schedules are provided for construction and future maintenance of the drainage works.

- Schedule A shows the assessment of the total estimated cost
- Schedule B will be used for prorating future maintenance cost
- Schedule C will be used for levying the final cost of the Drain and it indicates estimated net assessments after deducting grants and allowances where applicable.
- Appendix A illustrates the calculation of the assessments outlined in Schedule A.
- Appendix B illustrates the calculation of the assessments outlined in Schedule B.

2 BACKGROUND

On October 28, 2002, the City of Port Colborne had received a petition from landowners for drainage improvements for the Schihl Award Drain watershed in Lots 1 to 3, Concessions 4 and 5 (Humberstone Twp).

A letter was received from the City to K. Smart Associates Limited dated November 6, 2002 along with a copy of the petition. KSAL was to analyze the petition and set up an on-site meeting.

The first (on-site) meeting was held on December 4, 2002.

In late 2002-early 2003, an Engineering Services Agreement for the Schihl Drain was received from the City. The agreement was signed by John Kuntze, P.Eng. on May 6, 2003 and sent to the City.

In a letter dated June 23, 2003, KSAL was appointed by City of Port Colborne in Bylaw 4378/51/03 dated May 26, 2003 to authorize the City to enter into the agreement with K. Smart Associates Limited for the Schihl Drain. We have considered this to be an appointment as per the signed agreement by John Kuntze, P.Eng.

On February 1, 2007 a letter was sent to the City changing the Engineer from John Kuntze, P. Eng. to Chris Allen, P.Eng.

In accordance with Section 8(2) of the Act, on December 6, 2017 a letter was sent to the City changing the Engineer to Neal Morris, P.Eng.

A letter dated December 13, 2017 was received from the City appointing Neal Morris, P.Eng. in a resolution from the City on November 27, 2017, to prepare a drainage report for repair, improvement and incorporation of the Schihl Award Drain. This re-appointment became necessary due to an incorrect or incomplete appointment at the outset of this project, circa 2002, and to recognize the current Engineer of record, Neal Morris, P.Eng. This appointment was effective immediately and all requirements of the Drainage Act, RSO 1990 are considered to have been met at the time of the previous appointment of John Kuntze, P. Eng.

3 DRAINAGE HISTORY

There is an existing ditch that outlets into the St. John's Marsh Drain 2016, in Lot 14, Concession 14 NR (Bertie Twp) in the Town of Fort Erie, that is known as the Schihl Award Drain.

The Schihl Award Drain was constructed in accordance with a report of George Ross, P.Eng. dated September 17, 1909. It commenced at the St.'s John's Marsh Drain and continued westerly in Lot 14, Concession 14 NR and in Lots 13 and 14, Concessions 15 NR and 16 NR (Bertie Twp, now in the Town of Fort Erie) to the Townline Road (now Holloway Bay Road), then continued westerly in Lots 1 and 2,

Concession 5 (Humberstone Twp, now in the City of Port Colborne) then south along the east side of Road Lots 2-3 (now Regional Road 98 (Schi hl Road) and then west across the road. It was all open ditch and was 11,521' (3,511.6m) in length.

4 INVESTIGATION

4.1 On-Site Meeting

An on-site meeting was conducted on December 4, 2002. The meeting was held to review the drainage concerns with the affected landowners. All of the landowners in the watershed of the Schi hl Award Drain in the City of Port Colborne and Town of Fort Erie were notified. The meeting was held at 7:00 p.m. at the Port Colborne City Hall.

Those present and items discussed were as follows:

R. Singleton (Roll No. 13-086)

He indicated that several acres flood out.

He owns 15 acres. He has no buildings. The land is forest and marsh. There is a stone bridge on College Road. Done temporary work to get access for horse trail. He uses the property for cutting wood.

Mr. Noordhoer (776542 Ont. Ltd.) (Roll No's. 6-113, 6-072-15, 6-075, 6-121)

He has owned the property since 1958 and owns 4 parcels. In Lots 1 and 2, he indicated that several years ago, his tenant cleaned out the top end. There are no culverts and no need for them as he is surrounded by rock. Through the bush there is no path. One culvert is needed for work. The tenant made a ditch across the corner, along the bush. There are two ditches across Lot 3. None at Vallee's property. Along the road, ditch was cleaned, full of cattails, done by Region. Doesn't get much off the railroad. He thinks Anderson goes other way.

Mr. Koabel (Roll No. 6-119)

Clean culvert under tracks, been tiling to the front, been difficult for him to go east. Doesn't require drain to his property, just needs outlet into road ditch.

Mr. Harnach (Roll No. 6-114)

He gets no runoff from Harnach property.

Mr. Bertin (Roll No. 31-148) (now Swinson Property)

The creek is on his property. The land is much higher and the land falls into the creek. Even during flooding, his land is dry. No flooding. Large 5' dia. cast iron culvert through. He rents out his property.

R. Charron (Roll No. 31-094)

Residential. No comments.

Schihi Road (Region of Niagara)

Intermittent, dry most of the year. Road ditches along College Road flow east to St. John's Marsh Drain.

Equestrian do fund raising.

Water lays north of College, until August.

Unknown

Defined channel downstream of railroad. Just needs to be brushed and not graded.

Lee-Ann Hamilton (Niagara Peninsula Conservation Authority) (NPCA)

Fish habitat information collected for this drain which is consistent with a Class F drain.

4.2 Site Examination and Survey

The route of the existing Schihi Award Drain was examined in December 2002 and March 2003. A survey was undertaken in April-May 2003. A topographic (Total Station, GPS) survey was done in June and September 2004 and January 2018.

4.3 Watershed Description

The perimeter watershed of the Drain has been established based on site investigation, topographic data and historical reports.

The watershed area is approximately 59% agricultural lands, 25% forested lands, 12% residential lands and 4% roads.

The Schihi Drain has common watershed with the Young Drain, Tee Creek Drain 1993 and the Henry Drain 2006. The Schihi Drain lies within the greater watersheds of the St. John Marsh Drain 2016 and Black Creek Drainage Workes 2015.

5 AUTHORITY FOR REPORT

Section 4 of the Drainage Act provides for construction of new drainage works for an area requiring drainage. As a result of the analysis of the petition and of discussions at the on-site meeting and on-site examination, the area requiring drainage was determined to be the north part of Lots 1 to 3, Concession 4 and Lots 1 to 3, Concession 5, Humberstone Twp, now part of the City of Port Colborne. The signatures on the petition represent greater than 60% of the area in the area requiring drainage, thus the petition is valid in accordance with Section 4(1)(b) of the Drainage Act.

The Engineering Services Agreement and Bylaw 4378/51/03 dated May 26, 2003, and the letter from the City dated December 13, 2017, are the authorizations to prepare the report for the Schihi Drain.

6 DESIGN CONSIDERATIONS

6.1 Sufficient Outlet

Section 15 of the Act requires that proposed work be continued downstream to a sufficient outlet. Section 1 of the Act defines sufficient outlet as “a point at which water can be discharged safely so that it will do no damage to lands or roads.” For this project, it was determined that the St. John’s Marsh Drain 2016, which outlets into Black Creek Drain, provides sufficient outlet and will allow the proposed works to function as intended.

6.2 Drain Capacity (Sizing)

The recommended open ditch is designed for a 2 year storm event which provides adequate depth for tile drain outlets. It is customary for open municipal drains serving agricultural or rural lands to be sized for a 2-year storm. The ditch has been also sized to protect buildings from a 25-year storm event.

Laneway culverts are designed for the 5-year storm.

Municipal road crossings are designed for the 10-year storm.

Regional Road crossings are designed for the 25-year storm.

Railway crossing is designed so as to not overtop in a 100-year storm event.

This approach is in accordance with the “Guide for Engineers Working Under the Drainage Act in Ontario” OMAFRA Publication 852 and is in accordance with the Drainage Act.

6.3 Soil Conditions

The Region of Niagara soils map for this area indicates that the soils adjacent to this drain are lacustrine heavy clay and silty clay over clay loam till.

Based on available information, no adverse subsurface conditions are expected on this project and the use of conventional construction equipment is anticipated. Refer to the Standard Specifications for drain construction procedures when adverse subsurface conditions are encountered.

7 MEETING(S)

7.1 Public Information Meetings

February 24, 2004 (Second Meeting)

A meeting was held with all landowners, etc. in the watershed to discuss the minimum work required from the head of the drain from Forkes Road in the City of Port Colborne to just east of Burger Road in the Town of Fort Erie, and possible further work across and downstream of Point Abino Road.

Discussions with the landowners at the meeting indicated that the entire drain should be cleaned out/deepened and to analyze all existing culverts.

Those present at the meeting and items discussed are as follows:

Present:

Neil Nordic

William Myrmk (Willoyd Ltd.) (Roll No.31-137-01, 31-140)

Lee-Ann Hamilton (NPCA)

Robert Brost (Roll No. 13-162)

Rick Bertin (Roll No. 31-148)

Hanna Van Der Meer (Roll No. 31-141)

Brett Ruck (Town of Fort Erie) (Drainage Superintendent)

Rene Landry (City of Port Colborne)

John Kuntze, P. Eng. (K. Smart Associates Limited)

Items Discussed:

N. Nordic

- No plans to the property
- Concrete under Schihl years ago, filled in
- Townline Road used in summer
- Go south side, then jump to north side

W. Myrmk (31-137-01, 31-140)

- Problems at railroad and Point Abino Road
- Whirlpool created, ditch needs to be increased in size
- 1' over top of culvert
- Improvements upstream will put water on property, wants ditch cleaned out on his property
- 3 to 4 weeks of flooding conditions
- Worried all water is pushed onto them
- 2 to 3 weeks of flooding
- Wants 4' culvert under railroad bigger
- Will not have a problem downstream of railroad, home may have problems
- Who determined where drain was?
- Was to be a stream from Beardwood woodlot east, stopped at Burger Road

R. Bertin (31-148)

- Outlet of railroad is not backed up
- Will more water pile up or at railroad?
- (John – If culvert is not proper, can take a look)
- Worst Conditions
- Does downstream of railroad need to be done?
- Costs to replace culverts?
- Under Section 26
- Cost to go from Point Abino Road to Railroad?

R. Landry (City of Port Colborne)

- Culverts installed by City, costs are not included
- North side clearing preferred
- Won't look at cleaning road ditches unless there is no outlet, waste of money
- 3 years of cleaning, do all road ditches, unofficial policy

H. Van Der Meer (31-141)

- Is there fencing grants for livestock, permanent fencing?
- Relocation of drain is not a problem

R. Brost (31-162)

- Concerns regarding assessments, land drainage
- Feels more land is running south

B. Ruck (Drainage Superintendent, Town of Fort Erie)

- Problems with area
- With new outlet, road ditch maintenance to follow

J. Kuntze, P. Eng.

- Lands will flood, waters will flow away, not all culverts have to be replaced
- No analysis was done, because no concerns raised at first meeting
- Don't want all water to take off at once
- To satisfy petition, clean to railroad, anything downstream of railroad need more interest
- Fort Erie wants ditch downstream of Point Abino Road cleaned out for 400m±
- Would put in a new culvert on a skew, 50 to 60', Section 26, railroad pays
- Cannot address 2 easterly culverts
- Do analysis of Townline Road
- 1500' at 0.1% grade from Point Abino Road, provide better outlet for culverts
- Fort Erie is concerned
- Analysis of Point Abino culverts, rusted?
- Allowances
 - R.O.W
 - Loss of Access
 - 7.5m buffer strip
- Ditch outside of road allowances (Region)
- Move channel away from buildings, restrict livestock access
- Re Option #3
 - Look at Van Der Meer's culvert, flat bottom
 - Livestock out of channel;
 - Minimal excavation work
 - Brushing, allowances, engineering
- Land has to be looked at in terms of potential to be drained

July 11, 2017 (Third Meeting)

A further meeting was held with directly affected landowners in the watershed to discuss the findings/recommendations, preliminary costs, etc. to date.

Discussions with the landowners indicated that more work should be done in the ditch and at Regional Road 98 (Schihl Road) culverts should be investigated.

November 29, 2017 (Fourth Meeting)

On November 29, 2017, a further meeting was held. Those present and their comments are as follows:

Neal Morris, P. Eng. started the meeting and discussed the recommended work, preliminary costs and possible assessments to landowners and roads.

Roll No. 6-121, 6-113, 6-075

- Has drainage issues at minimum ditch to be cleaned out
- Provide estimate of tile drain cost options

Roll No. 31-165-10

- Railway and Burger Road culverts cause water to back up
- Says ditch is very shallow
- Wants culvert
- Can work on north side of ditch to pond then work on the south side opposite of his house.

Roll No. 31-164

- Has flooding problems
- Asked if ditch cleaning will stop his house from flooding

Roll No. 31-165

- Has flooding problems
- Can clean ditch on their property and sod

Roll No. 31-162

- Wanted watershed to be changed.

Town of Fort Erie

- Holloway Bay road culvert may be removed

January 15, 2019 (Fifth Meeting)

A further meeting was held with all landowners in the watershed being notified.

There were discussions with the landowners, City and Town staff present at the meeting:

The status of the investigations to date were presented along with a summary of the proposed/recommended Schihl Drain work and preliminary cost estimates and assessments. Aside from general questions related to the methodology used to determine assessments, there were no requests for design changes.

7.2 Other Meetings

October 28, 2004

A meeting was held with Brett Ruck (Drainage Superintendent, Town of Fort Erie) and KSAL staff to discuss possible work.

- Could get an outlet at old railway if no increased depth required upstream
- Need to clean out 450m± downstream of Point Abino road to get outlet for culverts

March 22, 2007

A status meeting was held with Brett Ruck.

- Initial appointment was by City of Port Colborne for a report on the Schihl Award Drain in Port Colborne.
- Site meetings (December 4, 2002) and surveys completed
- Could obtain outlet for Port Colborne lands at Railroad just east of Burger Road
- Owners in Fort Erie felt further work should be done on award drain in Fort Erie, Town noted possible problem at Point Abino Road
- Site examination and survey completed from Burger Road to St Johns Marsh Drain
- Preliminary design and cost has been completed
- Work remaining
 - Review preliminary cost and assessment for work in Fort Erie with Town and directly affected landowners

8 ENVIRONMENTAL CONSIDERATIONS

8.1 Agency Notification

Contact was made with the Niagara Peninsula Conservation Authority (NPCA), the Ministry of Natural Resources and Forestry (MNR) and Fisheries and Oceans Canada (DFO) during the process of preparing this report.

8.2 Agency Responses

8.2.1 NPCA

The NPCA did not request an environmental appraisal under Section 6 of the Act. The Conservation Authority received notice of public meetings conducted during the course of this project. On May 22, 2018 and January 14, 2019, meetings were held with NPCA staff at their office and they did not want to deepen the ditch through the

forest on Lot 2 but had no other concerns with the design. A permit is required before construction of the drain.

8.2.2 MNRF

A screening request for species at risk was submitted to MNRF on January 24 2019. We have had no response from MNRF at the time this report was submitted. Preliminary screens show that the drain is part of the Black Creek wetland complex and Small White Lady's-sliper and Eastern Meadowlark (2002) were observed in the area.

8.2.3 DFO

The Schihl Drain is not rated but outlets into a Class C drain under DFO's drain classification system.

A Request for Review was submitted to DFO along with a project description and drawing package on January 30, 2019. We have had no response from DFO at the time this report was submitted. Preliminary findings have indicated the proposed works are not likely to result in serious harm to fish. We have included erosion and sediment control measures.

9 RECOMMENDED WORK

A description of the Drain for construction and future maintenance can be found in the Special Provisions and Drawings.

9.1 Culverts

Table 9.1-1 – Summary of Culverts identifies culverts that are part of the Drain and specifies minimum capacity for future culverts, subject to the approval of the municipality as required by the Maintenance section of this report.

Table 9.1-1 - Summary of Culverts

Roll Number or Road	Station	Existing Length, Size, and Type	Proposed Recommended	Responsibility
Point Abino Road	0+758 to 0+776	Twin (2) 18m lengths of 1150mm high x 1450mm wide arch CSP's	Twin 18m lengths of 1120mm high x1630mm wide arch CSP's	Road
31-141	1+095	3 – 5.5m lengths of 900mm dia. CSP's	Twin 6m lengths of 900mm HDPE pipe	Drain
31-996 (old Railway)	1+743 to 1+760	17m of 1200mm dia. steel smooth wall pipe	17m length of 1200mm dia. steel smooth wall pipe	Utility Railway

Roll Number or Road	Station	Existing Length, Size, and Type	Proposed Recommended	Responsibility
Burger Road	1+890 to 1+899	9m of 1.85m wide x 0.75m high concrete culvert (no concrete bottom)	Twin 9m lengths of 1200mm CSP's aluminized or twin 970mm high x 1390mm wide arch CSP's aluminized	Road
31-165-10	2+055±	None	Twin (2) 4m lengths of 600mm dia. HDPE pipe (low flow crossing) (to be constructed by this report)	Drain
Holloway Bay Road	2+473 to 2+483	10m of 1.85m wide x 0.65m high concrete culvert with headwalls (no concrete bottom)	10m lengths of 750mm and 900mm dia. HDPE pipes	Road
Reg. Road 98 (Schi hl Road)	3+490 to 3+504	12.6m of 600mm dia. CSP	14m lengths of 750mm and 900mm dia. PPE pipes	Road
Reg. Road 98 (Forkes Road E)	3+525 to 3+537	12m of 900mm high x 1600mm wide arch CSP	14m lengths of 750mm and 900mm dia. PPE pipes	Road
Minimum capacity for future culverts, subject to municipality approval.				
31-086	0+000 to 0+150	None	Twin 6m lengths of 1050mm HDPE pipe	Drain
31-087	0+150 to 0+300	None	Twin 6m lengths of 1050mm HDPE pipe	Drain
31-088	0+300 to 0+395	None	Twin 6m lengths of 1050mm HDPE pipe	Drain
31-089	0+395 to 0+485	None	Twin 6m lengths of 1050mm HDPE pipe	Drain
31-094	0+485 to 0+754	None	Twin 6m lengths of 1050mm HDPE pipe	Drain

Roll Number or Road	Station	Existing Length, Size, and Type	Proposed Recommended	Responsibility
6-113	2+488 to 3+175	None	6m length of 1500mm CSP or triple 6m lengths of 900mm HDPE pipes	Drain

Based on the responsibility noted above, culverts constructed under this report are assessed as follows:

- Drain – 50% to the listed roll number and 50% to the upstream watershed
- Road – special assessment to the road authority per Section 26
- Road/Utility – 50% to the affected utility and 50% to the road authority
- Owner – 100% to the listed roll number

Refer to the Maintenance section of this report for instructions regarding assessing future culvert maintenance costs.

9.2 Changes to the Drain After the Bylaw is Passed

If a substantial addition, deletion, or change is made to the drain proposed in this report, a revised report can be prepared and processed through the Act, or an application can be made under the Act to the Drainage Tribunal to recognize the substantial addition, deletion or change. The application to the Tribunal must occur before final costs are levied.

10 CONSTRUCTION CONSIDERATIONS

10.1 Utilities and Pre-Construction Approvals

Before starting work, the Contractor shall ensure all public utilities are located and shall contact all landowners along the proposed drain route to determine the location of any private utilities. The Contractor is responsible for determining there are no utility conflicts for the proposed drainage works. No permits are required for the proposed work.

Utilities exist along Burger Road and Regional Road 98 but no conflicts are anticipated for the new Drain crossing across the road due to its close proximity to the existing crossing.

Work at Regional Road 98 road allowance is subject to approval and coordination with the Region of Niagara Roads Department.

10.2 Construction Scheduling

Construction cannot commence until 10 days after a bylaw to adopt this report is given third reading in accordance with the Act.

10.3 Minor Adjustments During Construction

Minor changes to the drain may be made during construction if the changes are approved by the Engineer and the Municipality in accordance with the Specifications in this report. Such changes must occur before final costs are levied.

Additional work desired by landowner(s) which is not part of the drainage works may be arranged with the Contractor provided the cost of the work is paid by the landowner(s) and the additional work is reviewed by the Engineer in advance. Such additional work is not part of the drainage works for future maintenance.

10.4 Substantial Alterations to the Drain

Any alterations that would affect the function of the drain which are requested by landowners, agencies or other authorities after the bylaw is passed cannot be undertaken unless the report is amended.

10.5 Alignment of Drains

All drains shall be constructed and maintained generally to the alignment as noted on the plans and specified by the Special Provisions. In the absence of survey bars, existing fences and similar boundary features are assumed to represent property lines.

Should landowners desire a more precise location for the drains in relation to their property line or if there is a dispute about the location of any property line, it is recommended that landowners obtain a legal survey at their own cost prior to construction.

11 DRAWINGS AND SPECIFICATIONS

11.1 Drawings

The location of the Drain, watershed boundary and the affected properties are shown on Drawing No. 1 included with this report. The numbers adjacent to the drain are station numbers which indicate in metres the distance along the drain from the outlet.

The profiles for the Drain are on Drawings 2 to 4. The profiles show the depth and grade for proposed work and future maintenance. Drawings 5 to 10 contain

additional details and cross-sections. Drawings No. 11 and 12 contain the Special Provisions and Standard drawings for construction and maintenance of the Drain.

11.2 Specifications

This report incorporates the General Conditions, Standard Specifications and Special Provisions listed in the Table of Contents which govern the construction and maintenance of the drain.

12 COST ESTIMATE

The estimated cost of this project includes allowances to owners, the construction cost, the engineering cost and other costs associated with the project.

12.1 Allowances

Sections 29 to 33 of the Drainage Act provides for allowances (compensation) to owners affected by proposed drain construction. On this project, there are only allowances for Sections 29 and 30.

12.1.1 Section 29 – Right of Way

Section 29 provides for payment of an allowance to landowners for right of way required for construction and maintenance of the new drain. This allowance compensates the owners for land to accommodate the drain, access routes to the drain and for a corridor along the drain for construction and maintenance purposes. Current municipal assessment rolls were reviewed to establish land values for computing right of way allowances. Section 29 allowances are based on the rates in the following Table.

Table 12.1-1 - Section 29 Allowance Rates

Land Use	Area Land Value
Cultivated Lands	\$ 3.11/m ²
Bush Lands	\$ 2.46/m ²

There is a minimum Section 29 (R-O-W) allowance of \$100.

12.1.2 Section 30 - Damages

Section 30 provides for payment of an allowance to landowners along the drain for damages caused by the construction of the drain. Where separate access routes to the working area are specified in this report, Section 30 allowances also account for access route damage. In agricultural areas, crop damages are computed based on published crop values and declining productivity loss in the years following construction. For this project, Section 30 allowances are based on the following rates:

Table 12.1-2 - Section 30 Allowance Rates

Land Use	Area Land Value
Cultivated Lands	\$ 0.43/m ²
Bush Lands	0.22/m ²

There is a minimum Section 30 (damage) allowance of \$100.

The table below summarizes the dimensions and amounts of the allowances to be provided under this report.

Table 12.1-3 - Summary of Allowances

Roll Number	R.O.W. Width (m)	Sec 29 (\$)	Damages Width (m)	Sec 30 (\$)	Total (\$)
Town of Fort Erie (27-03-020-0) (Former Township of Bertie)					
31-086	10	3,700	15	500	4,200
31-087	10	3,700	15	500	4,200
31-088	10	2,300	15	300	2,600
31-089	10	2,200	15	300	2,500
31-094	10	6,600	15	1,800	8,400
31-140	10	12,300	15	2,000	14,300
31-141	10	11,600	15	2,400	14,000
31-146	5	1,400	10	200	1,600
31-147	5	1,400	10	500	1,900
31-148	5	1,400	10	500	1,900
31-165	10	3,700	15	900	4,600
31-165-10	10	11,100	15	1,600	12,700
31-996	--	0	15	300	300
City of Port Colborne (27-11-040-00) (Former Twp of Humberstone)					
6-075	7.5	100	10	100	200
6-113	10	26,500	15	4,600	31,100
6-121	7.5	200	10	100	300
TOTAL ALLOWANCES:		88,200		16,600	104,800

In accordance with Section 62(3) of the Act, the allowances shown may be deducted from the final assessment levied. Payment to the owner would only be made when the allowance is greater than the final assessment. The allowances are a fixed amount and are not adjusted at the conclusion of construction.

12.2 Construction Cost Estimate

The estimated cost for Labour, Equipment and Materials to construct the proposed drain is outlined in detail in Estimated Costs Summary in Table 12.6-1 - Estimated Cost Summary. The construction cost estimate is based on recent costs for

comparable work. A contingency amount is included to cover additional work that may be required due to field conditions or minor alterations to the project.

The contract for the drain will be awarded by public tender. If the contract price is more than 33% over the engineer's estimate, Section 59 of the Act requires a Council meeting with the assessed landowners to determine if the project should proceed.

12.3 Engineering Cost Estimate

Engineering costs include report preparation and attending the Council meeting to consider report and the Court of Revision

Construction Phase Services may include: preparing tender documents and tender call, review of tenders, attending pre-construction meeting, periodic construction inspection, payments, final inspection, post construction follow-up, final cost analysis and preparation of the grant application.

The cost for report preparation is usually not altered at the conclusion of a project unless the report is referred back or the report is appealed to the Drainage Tribunal which would result in additional costs. The amount shown for meetings is an estimate. Final cost will be based on the actual time required for meetings. The estimate shown for construction phase services is based on past experience and assumes good construction conditions and a Contractor who completes the construction in an efficient manner. The final cost for the construction phase will vary as per the actual time spent during and following drain construction. Engineering costs are summarized in Table 12.6-1 - Estimated Cost Summary.

12.4 Estimate of Section 73 Costs

Section 73(2) and 73(3) of the Act direct that the cost of services provided by Municipal staff and Council to carry out the Act process shall not form part of the final cost of the drain. However, Section 73(1) outlines that the following costs incurred by the Municipality can be included in the cost of the drain: "*cost of any application, reference or appeal and the cost of temporary financing.*"

The estimate of Section 73 costs is included to cover the above referenced items from Section 73(1) and primarily provides for interest charges on financing the project until it is completed. This cost estimate may not be adequate to cover legal or engineering costs incurred by or assessed to the municipality should the project be appealed beyond the Court of Revision though such costs will form part of the final drain cost.

Grant policy indicates that Municipal cost for photo-copying and mailing required to carry out the required procedures under the Act can be included in the final drain cost. This cost estimate includes an allowance for these costs.

Section 73 costs are summarized in Table 12.6.1 Estimate Cost Summary.

12.5 Harmonized Sales Tax

The Harmonized Sales Tax (HST) will apply to most costs on this project. The Municipality is eligible for a partial refund on HST paid, the net 1.76% HST is included in the cost estimates in this report.

12.6 Estimated Cost Summary

Table 12.6-1 - Estimated Cost Summary

DESCRIPTION							FINAL COST
ALLOWANCES (from Table 12.1-3):							\$104,800
CONSTRUCTION COST ESTIMATE							
Item	Stations	Description	Unit	Quantity	Unit Price	Cost	
i) Main Drain							
1	0+00 to 0+050	No work required				\$ 0	
2	0+050 to 0+485	Power brushing 10m width on south side of drain	m ²	4,350	2	8,700	
3	0+050 to 0+758	708m of ditch cleanout, 2.5m wide bottom, 2:1 side slopes. Level spoil on south side of drain including incidental brushing Sta. 0+485 to 0+754	m	708	20	14,200	
4	0+050 to 0+758	Seeding of ditch banks (5m sides)	m ²	3,540	1	3,500	
5	0+752	Construct permanent rock sediment trap with 10m ² of riprap	each	1	2,200	2,200	
6	0+754 to 0+784	No work required. Existing twin (2) 18m lengths of 1150mm high x 1450mm wide arch CSP culverts to be incorporated				0	
7	0+776 to 1+050	274m of ditch cleanout, 2m wide bottom, 2:1 side slopes. Level spoil on south side including incidental brushing	m	274	20	5,500	
8	0+776 to 1+050	Seeding of ditch banks (5m sides)	m ²	1,370	1	1,400	
9	1+050 to 1+743	Excavate 693m of ditch, 2m wide bottom, 2:1 side slopes. Level spoil on south/north side	m	693	20	13,900	
10	1+050 to 1+743	Seeding of ditch banks (4m sides)	m ²	2,772	1	2,800	
11	1+095	Clean through existing 3 - 5.5m lengths of 900mm CSP culverts to design grade	m	12	40	500	
12	1+100 to 1+743	Power brush in ditch and 10m on south side/north side	m ²	5,060	2	10,100	
13	1+743 to 1+760	Clean through railway 1200mm dia. culvert to design grade (17m length)	m	17	40	700	
14	1+760 to 1+890	Excavate 130m of ditch, 2.0m wide bottom, 2:1 side slopes. Level spoil on south side	m	130	20	2,600	
15	1+760 to 1+884	Seeding of ditch banks (3m sides)	m ²	372	1	400	

DESCRIPTION							FINAL COST
16	1+760 to 1+884	Power brushing in ditch and 5m on north side	m ²	1,240	2	2,500	
17	1+880	Construct permanent rock sediment trap with 10m ³ of riprap	each	1	2,200	2,200	
18	1+889 to 1+899	Install 10m of 750mm dia. HDPE pipe beside existing culvert across road by open cut including restoration	L.S.	1	20,000	20,000	
19	1+904 to 2+317	Power brushing in ditch and 10m on south side	m ²	4,130	2	8,300	
20	1+899 to 2+468	Excavate 569m of ditch, 2, wide bottom, 2:1 side slopes. Level spoil on south side	m	569	20	11,300	
21	1+904 to 2+468	Seeding of ditch banks (4m sides)	m ²	2,256	1	2,300	
22	2+055±	Construct low flow crossing with twin (2) 4m lengths of 600mm dia. HDPE pipes and 40m ² of riprap	L.S.	1	4,000	4,000	
23	2+478	Clean through road culvert to design grade (10m length) and ditch at both ends	m	20	40	800	
24	2+484 to 2+625	Power brushing in ditch and 10m on south side	m ²	1,410	2	2,800	
25	2+488 to 2+625	Excavate 137m of ditch, 1.5m wide bottom, 2:1 side slopes. Level spoil on south side	m	137	20	2,800	
26	2+488 to 2+625	Seeding of ditch banks (4m sides)	ha	548	1	600	
27	2+625 to 3+010	Power brushing 10m of ditch	m ²	3,850	2	7,700	
28	2+625 to 3+010	385m of debris removal	m	385	8	3,100	
29	3+010 to 3+175	Excavate 165m of ditch, 1.5m wide bottom, 2:1 side slopes. Level spoil on south side	m	165	20	3,300	
30	3+010 to 3+175	Seeding of ditch banks (4m sides)	m ²	660	1	700	
31	3+175 to 3+200	Excavate 25m of ditch, 1.5m wide bottom, 2:1 side slopes. Level spoil on east side	m	25	20	500	
32	3+175 to 3+200	Seeding of ditch banks (2m sides)	m ²	50	1	100	
33	3+170	Construct permanent rock sediment trap with 10m ³ of riprap	each	1	2,200	2,200	
34	3+200 to 3+490	Excavate 290m of ditch, 0.9m wide bottom, 1.5:1 side slopes. Level spoil on east side	m ²	20	290	5,800	
35	3+200 to 3+490	Seeding of ditch banks (2m sides)	m ²	1	580	600	
36	3+490 to 3+504	Remove and dispose of existing culvert and install 14m lengths of 750mm and 900mm dia. PPE pipes across road by open cut, including restoration. Taper 5m of ditch at downstream and upstream ends.	L.S.	1	25,000	25,000	

DESCRIPTION							FINAL COST
35	3+504 to 3+525	Excavate 21m of ditch, 0.9m wide bottom, 1.5:1 side slopes. Level spoil on north side	m	21	20	500	
36	3+504 to 3+525	Seeding of ditch banks (2m sides)	m ²	42	1	100	
37	3+525 to 3+537	Remove and dispose of existing culvert and install 12m lengths of 750mm and 900mm dia. PPE pipes across road by open cut, including restoration. Taper 5m of ditch at downstream and upstream ends	L.S.	1	25,200	25,200	
Sub Total Part i)						198,900	
ii) Contingencies							
38		Lump sum contingency allowance	L.S.	1	20,000	20,000	
Net HST (1.76%)						3,850	
TOTAL CONSTRUCTION COST ESTIMATE:						222,750	
ENGINEERING COST ESTIMATE							
Report Preparation						35,818	
Consideration of Report Meeting						700	
Court of Revision						300	
Construction Phase Services						18,182	
Net HST (1.76%)						965	
TOTAL ENGINEERING COST ESTIMATE:						55,965	
SECTION 73 (OTHER) COSTS ESTIMATE							
Printing (50 KSAL plus 950 Town)						1,000	
Printing of Tender Documents						200	
Agencies Permit Fee						1,000	
Interest estimate						3,400	
Unforeseen costs						3,700	
Net HST (1.76%)						165	
TOTAL SECTION 73 (OTHER) COSTS ESTIMATE:						9,465	
TOTAL ESTIMATED COST:						\$392,980	

13 ASSESSMENTS

The Drainage Act requires that the total estimated cost be assessed to the affected lands and roads under the categories of Benefit (Section 22), Outlet Liability (Section 23), Injuring Liability (Section 23), Special Benefit (Section 24) and Increased Cost (Section 26). On this project assessment for Benefit, Special Benefit, Outlet Liability and Increased Cost (Special) Assessment are involved.

13.1 Calculation of Assessments

The method of calculating the assessments for the Drain is illustrated in Appendix A which has been included with this report. Appendix A divides the drain into intervals. The estimated cost for each interval is then determined. For each interval

the first step in the assessment calculation is to determine the benefit assessment to the affected lands and roads, then special assessments to roads and utilities are determined, where applicable. After deducting the total benefit and special assessments from the interval cost, the balance of the cost is then assessed as outlet liability on a per hectare basis to all lands and roads in the watershed.

13.2 Benefit Assessments (Section 22 and 24)

Section 22 benefits were determined based on the estimated value the drain provides to the property and are not proportional to watershed area.

Section 24 special benefit is assessed to lands where additional work or features are requested that have no effect on the function of the drain. Special benefit examples include hauling spoil offsite, aesthetic features and installing lateral drains. Non-grantable benefits relate to work that is not eligible for Grant according to the current OMAFRA policy. Non-proratable benefits are not used to determine the actual cost factor for the final cost levy. Some examples would be lateral drains, culverts or hauling of spoil. Columns with non-grantable and non-proratable are used to complete the final assessment. Table 13.2-1 - Benefit Assessments provides a summary of the benefit assessments. The Special Benefit to Roll No. 31-165-10 is for ½ of the cost of the new low flow crossing at Sta. 2+055±.

Table 13.2-1 - Benefit Assessments

Roll Number (Owner)	Location (Interval)	Section 22	Section 24	Total Benefit	Non- grantable	Non- proratable
31-086	1	5,300	-	5,300	-	-
31-087	1	5,300	-	5,300	-	-
31-088	1	3,300	-	3,300	-	-
31-089	1	3,200	-	3,200	-	-
31-094	1	9,400	-	9,400	-	-
31-141	1	4,900	-	4,900	-	-
Point Abino Road	1	16,000	-	16,000	-	-
31-140	2	18,200	-	18,200	-	-
31-141	2	16,800	-	16,800	-	-
31-146	2	4,100	-	4,100	-	-
31-147	2	5,500	-	5,500	-	-
31-148	2	6,200	-	6,200	-	-
31-996	2	16,000	-	16,000	-	-
Burger Road	2	16,000	-	16,000	-	-
31-165	3	5,600	-	5,600	-	-
31-165-10	3	15,300	2,000	17,300	-	2,000
½ Holloway Bay Road (Town of Fort Erie)	3	8,000	-	8,000	-	-

Roll Number (Owner)	Location (Interval)	Section 22	Section 24	Total Benefit	Non-grantable	Non-proratable
½ Holloway Bay Road (City of Port Colborne)	3	8,000	-	8,000	-	-
6-113	3	5,300	-	5,300	-	-
6-113	4	33,500	-	33,500	-	-
Reg. Road 98 (Schihl Road)	4	23,300	-	23,300	-	-
6-121	4	600	-	600	-	-
Reg. Road 98 (Schihl Road and Forkes Road)	5	20,100	-	20,100	-	-
6-075	5	1,400	-	1,400	-	-
6-113	5	3,300	-	3,300	-	-
6-121	5	2,300	-	2,300	-	-
TOTALS:		256,900	2,000	258,900	-	2,000

13.3 Outlet Liability Assessments (Section 23)

Section 23(3) of the Drainage Act states that outlet liability assessment is to be based on the volume and rate of flow of the water artificially caused to flow. To satisfy this requirement, the lands and roads in the watershed are assessed on a per hectare basis, with adjustments made to recognize the different amount of runoff generated by different land uses. The basis for the adjustments is 1 hectare of cleared agricultural land contributing both surface and subsurface water to the drain. Land uses with a different runoff rate are adjusted by the factors given in the Table 13.3-1 - Runoff Factors Table.

Table 13.3-1 - Runoff Factors Table

Land Use	Runoff factor
Agricultural	1
Forest	0.5
Built-up	1.5
Gravel Road	2
Paved Road	2.5

13.4 Increased Cost (Special) Assessments (Section 26)

Section 26 of the Drainage Act directs that any increased cost due to a public utility (utility) or road authority (road) shall be paid for by that utility or road. This assessment is known as a Special Assessment.

The estimated special assessments are presented in Table 13.4-1 – Estimated Special Assessments. The equivalent drain cost is based on the length of drain affected by the road allowance or utility right of way and the normal cost of drain

construction. The increased cost caused by the road or utility is determined by subtracting the equivalent drain cost from the construction and engineering costs.

Table 13.4-1 – Estimated Special Assessments

Sta.	Road/ Utility	Authority	Construction Cost	Engineering Cost	Equivalent Drain Cost	Net HST	Estimated Special Assess.
1+889 to 1+899	Burger Road	Town of Fort Erie	20,000	5,000	-200	435	25,235
3+490 to 3+504	Reg. Rd 98 (Schihl Road)	Region of Niagara	25,000	6,300	-280	545	31,565
3+525 to 3+537	Reg. Rd 98 (Forkes Road)	Region of Niagara	25,200	6,300	-280	550	31,770
TOTALS:			70,200	17,600	-760	1,530	88,570

The actual special assessments will be determined after construction by inserting the actual construction and engineering costs in the Special Assessments Table. Any additional costs identified by the Engineer will be added to the Special Assessment where appropriate.

The road authority or utility may elect to construct the drain within their right of way with their own forces. In this case, the special assessment is calculated by inserting zero for the construction cost.

If there are increased costs to the drain project due to a utility or road not listed in the Table above, a Special Assessment will be based on the actual costs incurred.

Special Assessments do not apply to future maintenance assessments.

13.5 Assessment Schedules

13.5.1 Schedule A- Schedule of Assessments

The estimated cost for the drainage works in this report is distributed among lands, roads and utilities as shown in Schedule A, the Schedule of Assessments. In Schedule A each parcel of land assessed has been identified by the municipal assessment roll number at the time of the preparation of this report. The size of each parcel was established using the assessment roll information. For convenience only, each parcel is also identified by the owner name(s) from the last revised assessment roll.

13.5.2 Schedule B -Schedule of Assessments for Maintenance

In accordance with Section 74 of the Act, the Drain shall be maintained by the municipality and the cost of maintenance shall be assessed to lands and roads upstream of the maintenance location, prorata with the amounts in Schedule B. The amounts in Schedule B are derived from the cost distribution shown in Appendix B, which has been included with this report, and will not be levied with the final cost of the drainage works.

Roll numbers are per the Municipality's last revised assessment roll, names included for convenience. Amounts are not payable at this time, they determine share of future maintenance cost. Determine grant eligibility at the time of maintenance cost levy.

Schedule B is divided into columns to reflect the different drain intervals where maintenance work may be undertaken. These column intervals assist in identifying upstream lands and roads to be assessed for future maintenance. The percentages shown in Schedule B determine the share of future maintenance to be levied to a property or road. For example, a \$1,000 beaver dam removal or repair will result in a \$50 assessment to a property with a 5% maintenance assessment.

A minimum assessments of 0.1% is to be applied to all future small lots in the watershed per affected interval.

13.5.3 Schedule C – Schedule for Actual Cost Bylaw

After the construction of the drain is certified complete by the Engineer the Municipality will determine the actual cost of the drain. Actual assessments will be determined by prorating the actual cost of the drain using Schedule C. Schedule C illustrates the estimated net assessments after deducting allowances and grants from the total assessments shown in Schedule A. Eligibility for grant will be confirmed by the Municipality at the time the actual cost is levied. Actual assessments in Schedule C will be levied to the owner of the identified parcel at the time the Actual Cost Bylaw is passed.

14 GRANT

In accordance with the provisions of Section 85 of the Act, a grant not exceeding 1/3 (33-1/3%) may be available on the assessments against lands used for agricultural purposes. Current OMAFRA grant policy defines agricultural lands as privately owned parcels of land which have the Farm Property Class Tax Rate. Based on Municipal assessment roll information, parcels that have the Farm Property Tax Class are identified with an 'F' in the first column of the assessment schedules.

Section 88 of the Act provides for the Municipality to apply for this grant after the construction of the drain is certified complete by the Engineer. The Municipality must confirm the Farm Property Tax Class on the assessed parcels at the time the grant application is completed and submitted to OMAFRA. OMAFRA has the authority to determine grant eligibility regardless of the designation herein.

If any portion of the drainage works is not eligible for grant, those ineligible costs have been separately identified in this report.

15 PRIVACY OF LANDS

Although a municipal drain is situated on the property of various landowners, one landowner may not enter another landowner's property by means of the drain. Persons authorized to enter private lands to carry out duties authorized under the Act include: Engineers (or their assistants), Contractors (or their assistants) and the appointed Drainage Superintendents (or their assistants).

16 MAINTENANCE

16.1 General

Section 74 of the Act requires the Drain, as outlined in this report, to be maintained by the Municipalities, and the cost of maintenance to be assessed to the upstream lands and roads prorata with the assessments in Schedule B. The portion of the Drain in the Town of Fort Erie shall be maintained by the Town of Fort Erie and the portion of the Drain in the City of Port Colborne shall be maintained by the City of Port Colborne.

All parties affected by the Drain, are encouraged to periodically inspect the drain and report any visible or suspected problems to their appropriate Municipality.

A right-of-way along the drain and access routes to the drain exist for the Municipality to maintain the drain. There is a 6m wide right-of-way on each side of the drain that shall remain free of obstructions. The cost for removing obstructions is the responsibility of the owner.

Any landowner making a new connection to the Drain, shall notify the Drainage Superintendent before making the connection. If the Drainage Superintendent is not notified, the cost to remedy new connections that obstruct or otherwise damage the drain will be the responsibility of the owner.

The discharge of anything but clean, unpolluted water into a drain is regulated by other provincial legislation. Any non-compliance will be reported to the appropriate environmental agency.

It is recommended that each abutting owner work no closer than 1.2m (4') to any ditch bank. Such area does not have to be grassed but it should not be cultivated.

16.2 Updating Future Maintenance Schedules

To ensure future maintenance assessments are equitable, the assessments provided in this report should be reapportioned under Section 65 when severances or amalgamations occur, when new lands are connected to the Drain or when a land-use change occurs that can be accommodated by the existing Drain. If a future land-use change will cause the drain capacity to be exceeded, a report under Section 4 or 78 may be required to provide increased capacity.

16.3 Culvert Maintenance

- The costs of cleaning through all culverts shall be assessed as drain maintenance to upstream lands and roads.
- The cost for future structural repair, extension or replacement of road culverts will be assessed fully to the road authority.
- In Table 9.1-1, when the responsibility for an access culvert is designated as "Drain," the cost for repair or replacement shall be assessed 50% to the abutting landowner and the remainder to the upstream watershed. The cost of additional culverts and/or culvert length is assessed to the owner.
- In Table 9.1-1, when the responsibility for an access culvert is designated as "Owner," the cost for installation, repair, replacement and removal are the responsibility of the roll number listed.
- Culverts installed to service public utilities shall be assessed 50% to the utility and 50% to the affected land or road.
- Prior approval of the Municipality is required before a landowner installs a culvert not constructed under this report. The culvert shall be installed per sizing listed in Table 9.1-1 and design grade specified in this report. If culverts smaller than the minimum recommended size are installed, such culverts will be deemed an obstruction to the drain and removed at the landowner's expense.

17 BYLAW

This report including the drawings and specifications, assessment schedules and appendices, when adopted by bylaw in accordance with the Act, provides the basis for construction and maintenance of the Drain.

All of which is respectfully submitted,

K. SMART ASSOCIATES LTD.



N. Morris, P. Eng.

mw



**SCHEDULE A - SCHEDULE OF ASSESSMENTS
SCHIHL DRAIN
Town of Fort Erie and City of Port Colborne**

Conc.	Lot	Roll No.	Owner(s)	Total Ha Affected	Benefit (\$)	Outlet (\$)	Total (\$)
<u>Town of Fort Erie (27-03-020-0) (Former Township of Bertie)</u>							
<u>Lands</u>							
14NR	Pt 14	31-086-00	R. Singleton	1.7	5,300	38	5,338
14NR	Pt 14	31-087-00	J. Robertson & S. Cavey	2.1	5,300	47	5,347
14NR	Pt 14	31-088-00	D. Merritt	1.9	3,300	43	3,343
14NR	Pt 14	31-089-00	D. Merritt	1.9	3,200	43	3,243
14NR	Pt 13	31-093-00	C. Wegelin	0.3	24	13	37
14NR	Pt 14	31-094-00	R. Charron	2.8	9,400	121	9,521
14NR	Pt 14	31-096-00	R. & D. Willick	2.3	0	52	52
15NR	Pt 12	31-137-01	J. Mymryk	0.9	0	104	104
15NR	Pts 13&14	31-140-00	Willoyd Ltd.	36.8	18,200	4,011	22,211
15NR	Pt 14	31-141-00	H. Van Der Meer	6.0	21,700	695	22,395
15NR	Pt 14	31-142-00	K. & S. Sider	1.8	0	313	313
15NR	Pt 14	31-143-00	W. & S. Kikkert	1.8	0	313	313
15NR	Pt 14	31-144-00	D. Dagesse & D. Holloway	1.8	0	313	313
15NR	Pt 14	31-145-00	L. & A. Smith	1.8	0	313	313
15NR	Pt 14	31-146-00	W. Yuan & G. Li	3.0	4,100	243	4,343
15NR	Pt 14	31-147-00	C. Stackwood	2.3	5,500	400	5,900
15NR	Pt 14	31-148-00	R. & A. Swinson	6.9	6,200	799	6,999
16NR	Pt 11	31-160-04	P. Potts	2.5	0	183	183
16NR	Pts 11&12	31-162-00	R. Brost & T. Chute	19.7	0	2,570	2,570
16NR	Pt 13	31-162-01	P. & A. Brunet	8.9	0	1,515	1,515
16NR	Pt 13	31-163-00	D. Cregheur	6.3	0	659	659
16NR	Pt 13	31-164-00	C. Mugas & K. Beardwood	0.8	0	176	176
16NR	Pt 13	31-165-00	W. & K. Hawkins	2.5	5,600	330	5,930
16NR	Pt 14	31-165-10	D. & T. Brewster	5.0	17,300	425	17,725
16NR	Pt 14	31-165-15	A. & J. Natale	0.9	0	198	198
16NR	Pt 14	31-165-17	A. & J. Natale	1.6	0	352	352
16NR	Pt 14	31-166-00	H. & S. Dyck	1.7	0	373	373
16NR	Pt 14	31-166-02	J. Brooks	0.4	0	88	88
16NR	Pt 14	31-172-22	Town of Fort Erie	1.3	0	285	285
16NR	Pt 14	31-172-24	A. & J. Natale	2.0	0	439	439
15&16NR	Pts 13&14	31-996-00	C P Rail - Caso	5.8	16,000	1,085	17,085
Sub-Total (Lands):				135.5	121,124	16,539	137,663
<u>Roads</u>							
Point Abino Road			Town of Fort Erie	1.1	16,000	123	16,123
Burger Road			Town of Fort Erie	1.6	16,000	463	16,463
Special Assess. to Burger Road				0	25,235	0	25,235
1/2 Holloway Bay Road			Town of Fort Erie	1.2	8,000	176	8,176
Fox Road			Town of Fort Erie	1.4	0	489	489
Sub-Total (Roads):				5.3	65,235	1,251	66,486
Total Assessments for Town of Fort Erie:				140.8	186,359	17,790	204,149
<u>City of Port Colborne (27-11-040-00) (Former Twp of Humberstone)</u>							
<u>Lands</u>							
4	Pts 1&2	6-072-15	776542 Ont. Ltd.	19.0	0	2,424	2,424
4	Pt 3	6-075-00	776542 Ont. Ltd.	14.2	1,400	2,354	3,754
4	Pt 4	6-078-00	D. & S. Anderson	10.8	0	1,267	1,267
5	Pts 1&2	6-113-00	776542 Ont. Ltd.	46.1	42,100	7,908	50,008
5	Pts 1&2	6-114-00	S. & J. Hwang	13.9	0	2,596	2,596
5	Pts 3&4	6-119-00	Loeffen Farms Ltd.	1.6	0	155	155
5	Pts 3&4	6-120-00	2144894 Ont Ltd	1.5	0	144	144
5	Pts 3&4	6-121-00	776542 Ontario Ltd	39.3	2,900	7,160	10,060
5	Pt 4	6-122-00	P. Aiello	2.8	0	490	490
5	Pts 1 to 4	6-996-00	C.P.Rail-Caso	3.0	0	865	865
Sub-Total (Lands):				152.2	46,400	25,363	71,763
<u>Roads</u>							
Reg. Rd. 98 (Schihl Rd. & Forkes Rd)			Region of Niagara	2.8	43,400	1,377	44,777
Special Assess. to Reg. Rd 98 (Schihl Rd & Forkes Rd)					63,335	0	63,335
1/2 Holloway Bay Road			City of Port Colborne	1.8	8,000	265	8,265
Forkes Road			City of Port Colborne	1.2	0	550	550
Zavitv Road			City of Port Colborne	0.7	0	141	141
Sub-Total (Roads):				6.5	114,735	2,333	117,068
Total Assessments for City of Port Colborne:				158.7	161,135	27,696	188,831
TOTAL ASSESSMENTS FOR SCHIHL DRAIN:				299.5	347,494	45,486	392,980

Note:

Section 21 of the Drainage Act, RSO 1990 requires that assessments be shown opposite each parcel of land and road affected. The affected parcels of land have been identified using the roll number from the last revised assessment roll for the Township. For convenience only, the owners' names as shown by the last revised assessment roll, has also been included.

**SCHEDULE B - SCHEDULE OF ASSESSMENTS FOR FUTURE MAINTENANCE
SCHIHL DRAIN
Town of Fort Erie and City of Port Colborne**

Lot	Conc.	Roll No.	Owner(s)	Interval 1		Interval 2		Interval 3		Interval 4		Interval 5		TOTAL	
				Sta. 0+000	to 0+777	Sta. 0+777	to 1+904	Sta. 1+904	to 2+478	Sta. 2+478	to 3+200	Sta. 3+200	to 3+541	\$	%
				Assess.	%	Assess.	%	Assess.	%	Assess.	%	Assess.	%		
Town of Fort Erie (27-03-020-0) (Former Township of Bertie)															
Lands															
14NR	Pt 14	31-086-00	R. Singleton	326	4.18	-	-	-	-	-	-	-	-	326	0.92
14NR	Pt 14	31-087-00	J. Robertson & S. Cavey	330	4.23	-	-	-	-	-	-	-	-	330	0.93
14NR	Pt 14	31-088-00	D. Merritt	218	2.79	-	-	-	-	-	-	-	-	218	0.62
14NR	Pt 14	31-089-00	D. Merritt	208	2.67	-	-	-	-	-	-	-	-	208	0.59
14NR	Pt 13	31-093-00	C. Wegelin	8	0.10	-	-	-	-	-	-	-	-	8	0.02
14NR	Pt 14	31-094-00	R. Charron	611	7.83	-	-	-	-	-	-	-	-	611	1.73
14NR	Pt 14	31-096-00	R. & D. Willick	22	0.28	-	-	-	-	-	-	-	-	22	0.06
15NR	Pt 12	31-137-01	J. Mymryk	17	0.22	22	0.19	-	-	-	-	-	-	39	0.11
15NR	Pts 13&14	31-140-00	Willoyd Ltd.	650	8.33	1,998	17.68	-	-	-	-	-	-	2,648	7.48
15NR	Pt 14	31-141-00	H. Van Der Meer	113	1.45	1,225	10.84	-	-	-	-	-	-	1,338	3.78
15NR	Pt 14	31-142-00	K. & S. Sider	51	0.65	65	0.58	-	-	-	-	-	-	116	0.33
15NR	Pt 14	31-143-00	W. & S. Kikkert	51	0.65	65	0.58	-	-	-	-	-	-	116	0.33
15NR	Pt 14	31-144-00	D. Dagesse & D. Holloway	51	0.65	65	0.58	-	-	-	-	-	-	116	0.33
15NR	Pt 14	31-145-00	L. & A. Smith	51	0.65	65	0.58	-	-	-	-	-	-	116	0.33
15NR	Pt 14	31-146-00	W. Yuan & G. Li	39	0.50	211	1.87	-	-	-	-	-	-	250	0.71
15NR	Pt 14	31-147-00	C. Stackwood	65	0.83	253	2.24	-	-	-	-	-	-	318	0.90
15NR	Pt 14	31-148-00	R. & A. Swinson	129	1.65	337	2.98	-	-	-	-	-	-	466	1.32
16NR	Pt 11	31-160-04	P. Potts	23	0.29	30	0.27	17	0.30	-	-	-	-	70	0.20
16NR	Pts 11&12	31-162-00	R. Brost & T. Chute	329	4.22	424	3.75	244	4.28	-	-	-	-	997	2.82
16NR	Pt 13	31-162-01	P. & A. Brunet	194	2.49	250	2.21	144	2.53	-	-	-	-	588	1.66
16NR	Pt 13	31-163-00	D. Cregheur	84	1.08	109	0.96	63	1.11	-	-	-	-	256	0.72
16NR	Pt 13	31-164-00	C. Mugas & K. Beardwood	23	0.29	29	0.26	17	0.30	-	-	-	-	69	0.19
16NR	Pt 13	31-165-00	W. & K. Hawkins	42	0.54	54	0.48	641	11.25	-	-	-	-	737	2.08
16NR	Pt 14	31-165-10	D. & T. Brewster	54	0.69	70	0.62	1,330	23.33	-	-	-	-	1,454	4.11
16NR	Pt 14	31-165-15	A. & J. Natale	25	0.32	33	0.29	19	0.33	-	-	-	-	77	0.22
16NR	Pt 14	31-165-17	A. & J. Natale	45	0.58	58	0.51	33	0.58	-	-	-	-	136	0.38
16NR	Pt 14	31-166-00	H. & S. Dyck	48	0.62	62	0.55	36	0.63	-	-	-	-	146	0.41
16NR	Pt 14	31-166-02	J. Brooks	11	0.14	15	0.13	8	0.14	-	-	-	-	34	0.10
16NR	Pt 14	31-172-22	Town of Fort Erie	37	0.47	47	0.42	27	0.47	-	-	-	-	111	0.31
16NR	Pt 14	31-172-24	A. & J. Natale	56	0.72	73	0.65	42	0.74	-	-	-	-	171	0.48
15&16NR	Pts 13&14	31-996-00	C P Rail - Caso	163	2.09	1,100	9.73	36	0.63	-	-	-	-	1,299	3.67
Sub-Total (Lands):				4,074	52.20	6,660	58.95	2,657	46.62	-	-	-	-	13,391	37.84
Roads															
Point Abino Road				822	10.54	-	-	-	-	-	-	-	-	822	2.32
Burger Road				75	0.96	987	8.73	-	-	-	-	-	-	1,062	3.00
1/2 Holloway Bay Road				23	0.29	29	0.26	492	8.63	-	-	-	-	544	1.54
Fox Road				66	0.85	85	0.75	38	0.67	-	-	-	-	189	0.53
Sub-Total (Roads):				986	12.64	1,101	9.74	530	9.30	-	-	-	-	2,617	7.39
Total Assessments for Town of Fort Erie:				5,060	64.84	7,761	68.69	3,187	55.92	-	-	-	-	16,008	45.23
City of Port Colborne (27-11-040-00) (Former Twp of Humberstone)															
Lands															
4	Pts 1&2	6-072-15	776542 Ont. Ltd.	292	3.74	376	3.33	217	3.81	60	0.83	86	2.53	1,031	2.91
4	Pt 3	6-075-00	776542 Ont. Ltd.	219	2.81	283	2.50	163	2.86	258	3.58	644	18.94	1,567	4.43
4	Pt 4	6-078-00	D. & S. Anderson	118	1.51	152	1.35	88	1.54	139	1.93	201	5.91	698	1.97
5	Pts 1&2	6-113-00	776542 Ont. Ltd.	771	9.88	994	8.80	572	10.04	3,066	42.58	539	15.85	5,942	16.79
5	Pts 1&2	6-114-00	S. & J. Hwang	253	3.24	326	2.88	188	3.30	298	4.14	-	-	1,065	3.01
5	Pts 3&4	6-119-00	Loeffen Farms Ltd.	15	0.19	19	0.17	11	0.19	18	0.25	-	-	63	0.18
5	Pts 3&4	6-120-00	2144894 Ont Ltd	14	0.18	18	0.16	10	0.18	17	0.24	-	-	59	0.17
5	Pts 3&4	6-121-00	776542 Ontario Ltd	695	8.91	896	7.93	516	9.05	817	11.35	395	11.62	3,319	9.38
5	Pt 4	6-122-00	P. Aiello	48	0.62	62	0.55	36	0.63	56	0.78	-	-	202	0.57
		6-996-00	C.P.Rail-Caso	84	1.08	109	0.96	63	1.11	99	1.38	-	-	355	1.00
Sub-Total (Lands):				2,509	32.16	3,235	28.63	1,864	32.71	4,828	67.06	1,865	54.85	14,301	40.41
Roads															
Reg. Rd. 98 (Schihl Rd. & Forkes Rd)				128	1.67	170	1.49	97	1.68	2,313	32.12	1,449	42.62	4,157	11.72
1/2 Holloway Bay Road				34	0.44	44	0.39	500	8.77	-	-	-	-	578	1.63
Forkes Road				56	0.72	73	0.65	42	0.74	44	0.61	64	1.88	279	0.79
Zavitz Road				13	0.17	17	0.15	10	0.18	15	0.21	22	0.65	77	0.22
Sub-Total (Roads):				231	3.00	304	2.68	649	11.37	2,372	32.94	1,535	45.15	5,091	14.36
Total Assessments for City of Port Colborne:				2,740	35.16	3,539	31.31	2,513	44.08	7,200	100.00	3,400	100.00	19,392	54.77
TOTAL ASSESSMENTS FOR SCHIHL DRAIN:				7,800	100.00	11,300	100.00	5,700	100.00	7,200	100.00	3,400	100.00	35,400	100.00

Note:
Section 21 of the Drainage Act, RSO 1990 requires that assessments be shown opposite each parcel of land and road affected. The affected parcels of land have been identified using the roll number from the last revised assessment roll for the Township. For convenience only, the owners' names as shown by the last revised assessment roll, has also been included.

**SCHEDULE C - SCHEDULE FOR ACTUAL COST BYLAW
SCHIHL DRAIN
Town of Fort Erie and City of Port Colborne**

Lot	Conc.	Roll No.	Owner(s)	Gross Total (\$)	1/3 Grant (\$)	Allowance (\$)	Net (\$)
<u>Town of Fort Erie (27-03-020-0) (Former Township of Bertie)</u>							
<u>Lands</u>							
14NR	Pt 14	31-086-00	R. Singleton	5,338	-	4,200	1,138
14NR	Pt 14	31-087-00	J. Robertson & S. Cavey	5,347	-	4,200	1,147
14NR	Pt 14	31-088-00	D. Merritt	3,343	-	2,600	743
14NR	Pt 14	31-089-00	D. Merritt	3,243	-	2,500	743
14NR	Pt 13	31-093-00	C. Wegelin	37	-	-	37
14NR	Pt 14	31-094-00	R. Charron	9,521	-	8,400	1,121
14NR	Pt 14	31-096-00	R. & D. Willick	52	-	-	52
F 15NR	Pt 12	31-137-01	J. Mymryk	104	35	-	69
F 15NR	Pts 13&14	31-140-00	Willoyd Ltd.	22,211	7,404	14,300	507
F 15NR	Pt 14	31-141-00	H. Van Der Meer	22,395	7,465	14,000	930
15NR	Pt 14	31-142-00	K. & S. Sider	313	-	-	313
15NR	Pt 14	31-143-00	W. & S. Kikkert	313	-	-	313
15NR	Pt 14	31-144-00	D. Dagesse & D. Holloway	313	-	-	313
15NR	Pt 14	31-145-00	L. & A. Smith	313	-	-	313
15NR	Pt 14	31-146-00	W. Yuan & G. Li	4,343	-	1,600	2,743
15NR	Pt 14	31-147-00	C. Stackwood	5,900	-	1,900	4,000
F 15NR	Pt 14	31-148-00	R. & A. Swinson	6,999	2,333	1,900	2,766
16NR	Pt 11	31-160-04	P. Potts	183	-	-	183
F 16NR	Pts 11&12	31-162-00	R. Brost & T. Chute	2,570	857	-	1,713
F 16NR	Pt 13	31-162-01	P. & A. Brunet	1,515	505	-	1,010
16NR	Pt 13	31-163-00	D. Cregheur	659	-	-	659
16NR	Pt 13	31-164-00	C. Mugas & K. Beardwood	176	-	-	176
16NR	Pt 13	31-165-00	W. & K. Hawkins	5,930	-	4,600	1,330
16NR	Pt 14	31-165-10	D. & T. Brewster	17,725	-	12,700	5,025
16NR	Pt 14	31-165-15	A. & J. Natale	198	-	-	198
16NR	Pt 14	31-165-17	A. & J. Natale	352	-	-	352
16NR	Pt 14	31-166-00	H. & S. Dyck	373	-	-	373
16NR	Pt 14	31-166-02	J. Brooks	88	-	-	88
16NR	Pt 14	31-172-22	Town of Fort Erie	285	-	-	285
16NR	Pt 14	31-172-24	A. & J. Natale	439	-	-	439
15&16NR	Pts 13&14	31-996-00	C P Rail - Caso	17,085	-	300	16,785
Sub-Total (Lands):				137,663	18,599	73,200	45,864
<u>Roads</u>							
Point Abino Road			Town of Fort Erie	16,123	-	-	16,123
Burger Road			Town of Fort Erie	16,463	-	-	16,463
Special Assess. to Burger Road				25,235	-	-	25,235
1/2 Holloway Bay Road			Town of Fort Erie	8,176	-	-	8,176
Fox Road			Town of Fort Erie	489	-	-	489
Sub-Total (Roads):				66,486	-	-	66,486
Total Assessments for Town of Fort Erie:				204,149	18,599	73,200	112,350
<u>City of Port Colborne (27-11-040-00) (Former Twp of Humberstone)</u>							
<u>Lands</u>							
F 4	Pts 1&2	6-072-15	776542 Ont. Ltd.	2,424	808	-	1,616
F 4	Pt 3	6-075-00	776542 Ont. Ltd.	3,754	1,251	200	2,303
4	Pt 4	6-078-00	D. & S. Anderson	1,267	-	-	1,267
F 5	Pts 1&2	6-113-00	776542 Ont. Ltd.	50,008	16,669	31,100	2,239
F 5	Pts 1&2	6-114-00	S. & J. Hwang	2,596	865	-	1,731
F 5	Pts 3&4	6-119-00	Loeffen Farms Ltd.	155	52	-	103
5	Pts 3&4	6-120-00	2144894 Ont Ltd	144	-	-	144
F 5	Pts 3&4	6-121-00	776542 Ontario Ltd	10,060	3,353	300	6,407
5	Pt 4	6-122-00	P. Aiello	490	-	-	490
5	Pts 1 to 4	6-996-00	C.P.Rail-Caso	865	-	-	865
Sub-Total (Lands):				71,763	22,998	31,600	17,165
<u>Roads</u>							
Reg. Rd. 98 (Schihl Rd. & Forkes Rd)			Region of Niagara	44,777	-	-	44,777
Special Assess. to Reg. Rd 98 (Schihl Rd & Forkes Rd)				63,335	-	-	63,335
1/2 Holloway Bay Road			City of Port Colborne	8,265	-	-	8,265
Forkes Road			City of Port Colborne	550	-	-	550
Zavitv Road			City of Port Colborne	141	-	-	141
Sub-Total (Roads):				117,068	-	-	117,068
Total Assessments for City of Port Colborne:				188,831	22,998	31,600	134,233
TOTAL ASSESSMENTS FOR SCHIHL DRAIN:				392,980	41,597	104,800	246,583

Notes:

- The above lands marked "F" are currently classified as agricultural according to the OMAFA and are therefore entitled to a 1/3 grant .
- Section 21 of the Drainage Act, RSO 1990 requires that assessments be shown opposite each parcel of land and road affected. The affected parcels of land have been identified using the roll number from the last revised assessment roll for the Town. For convenience only, the owners' names as shown by the last revised assessment roll, has also been included.
- The value of the assessments identified in this schedule are estimates only, and should not be considered final.

**APPENDIX A - CALCULATION OF ASSESSMENTS FOR SCHEDULE A
SCHIHL DRAIN
Town of Fort Erie and City of Port Colborne**

				Interval 1				Interval 2				Interval 3				Interval 4				Interval 5				TOTAL					
				Sta.	0+000	to	0+777	Sta.	0+777	to	1+904	Sta.	1+904	to	2+478	Sta.	2+478	to	3+200	Sta.	3+200	to	3+541						
COST ESTIMATE:				21,900				34,000				17,300				23,100				8,500				104,800					
Allowances:																													
Construction:				32,055				70,115				29,915				26,660				64,005				222,750					
Engineering:				5,090				20,350				2,035				12,210				16,280				55,965					
Administration:				1,425				3,460				1,220				1,425				1,935				9,465					
Total Cost Estimate:				60,470				127,925				50,470				63,395				90,720				392,980					
Conc.	Lot	Roll No.	Owner	Total Affected (Ha)	Total Adjusted (Ha)	Benefit (\$)	Adjusted (Ha)	Outlet (\$)	%	Benefit (\$)	Adjusted (Ha)	Outlet (\$)	%	Benefit (\$)	Adjusted (Ha)	Outlet (\$)	%	Benefit (\$)	Adjusted (Ha)	Outlet (\$)	%	Benefit (\$)	Adjusted (Ha)	Outlet (\$)	%	Total Benefit	Total Outlet	TOTAL	
Town of Fort Erie (27-03-020-0) (Former Township of Bertie)																													
Lands																													
14NR	Pt 14	31-086-00	R. Singleton	1.7	0.85	5,300	0.85	38	8.83	-	0	0	0	-	0	0	0	-	0	0	0	-	0	0	0	5,300	38	5,338	
14NR	Pt 14	31-087-00	J. Robertson & S. Cavey	2.1	1.05	5,300	1.05	47	8.84	-	0	0	0	-	0	0	0	-	0	0	0	-	0	0	0	5,300	47	5,347	
14NR	Pt 14	31-088-00	D. Merritt	1.9	0.95	3,300	0.95	43	5.53	-	0	0	0	-	0	0	0	-	0	0	0	-	0	0	0	3,300	43	3,343	
14NR	Pt 14	31-089-00	D. Merritt	1.9	0.95	3,200	0.95	43	5.36	-	0	0	0	-	0	0	0	-	0	0	0	-	0	0	0	3,200	43	3,243	
14NR	Pt 13	31-093-00	C. Wegelin	0.3	0.30	24	0.30	13	0.06	-	0	0	0	-	0	0	0	-	0	0	0	-	0	0	0	24	13	37	
14NR	Pt 14	31-094-00	R. Charron	2.8	2.70	9,400	2.70	121	15.74	-	0	0	0	-	0	0	0	-	0	0	0	-	0	0	0	9,400	121	9,521	
14NR	Pt 14	31-096-00	R. & D. Willick	2.3	1.15	-	1.15	52	0.09	-	0	0	0	-	0	0	0	-	0	0	0	-	0	0	0	0	52	52	
15NR	Pt 12	31-137-01	J. Mymryk	0.9	0.90	-	0.90	40	0.07	-	0	0	0	-	0	0	0	-	0	0	0	-	0	0	0	0	40	104	
15NR	Pts 13&14	31-140-00	Willoyd Ltd.	36.8	34.65	34.65	1,553	2.57	18,200	34.65	2,458	16.15	16.15	-	0	0	0	-	0	0	0	-	0	0	0	18,200	4,011	22,211	
15NR	Pt 14	31-141-00	H. Van Der Meer	6.0	6.00	4,900	6.00	269	8.55	16,800	6.00	426	13.47	-	0	0	0	-	0	0	0	-	0	0	0	21,700	695	22,395	
15NR	Pt 14	31-142-00	K. & S. Sider	1.8	2.70	2.70	121	0.20	2.70	2.70	192	0.15	0.15	-	0	0	0	-	0	0	0	-	0	0	0	0	313	313	
15NR	Pt 14	31-143-00	W. & S. Kikkert	1.8	2.70	2.70	121	0.20	2.70	2.70	192	0.15	0.15	-	0	0	0	-	0	0	0	-	0	0	0	0	313	313	
15NR	Pt 14	31-144-00	D. Dagesse & D. Holloway	1.8	2.70	2.70	121	0.20	2.70	2.70	192	0.15	0.15	-	0	0	0	-	0	0	0	-	0	0	0	0	313	313	
15NR	Pt 14	31-145-00	L. & A. Smith	1.8	2.70	2.70	121	0.20	2.70	2.70	192	0.15	0.15	-	0	0	0	-	0	0	0	-	0	0	0	0	313	313	
15NR	Pt 14	31-146-00	W. Yuan & G. Li	3.0	2.10	2.10	94	0.16	4,100	2.10	149	3.32	3.32	-	0	0	0	-	0	0	0	-	0	0	0	4,100	243	4,343	
15NR	Pt 14	31-147-00	C. Stackwood	2.3	3.45	3.45	155	0.26	5,500	3.45	245	4.49	4.49	-	0	0	0	-	0	0	0	-	0	0	0	5,500	400	5,900	
15NR	Pt 14	31-148-00	R. & A. Swinson	6.9	6.90	6.90	309	0.51	6,200	6.90	490	5.23	5.23	-	0	0	0	-	0	0	0	-	0	0	0	6,200	799	6,999	
16NR	Pt 11	31-160-04	P. Potts	2.5	1.25	1.25	56	0.09	1.25	1.25	89	0.07	0.07	1.25	38	0.08	0.08	-	0	0	0	-	0	0	0	0	183	183	
16NR	Pts 11&12	31-162-00	R. Brost & T. Chute	19.7	17.55	17.55	787	1.30	17,550	17.55	1,245	0.97	0.97	17,550	538	1.07	1.07	-	0	0	0	-	0	0	0	0	2,570	2,570	
16NR	Pt 13	31-162-01	P. & A. Brunet	8.9	10.35	10.35	464	0.77	10.35	10.35	734	0.57	0.57	10.35	317	0.63	0.63	-	0	0	0	-	0	0	0	0	1,515	1,515	
16NR	Pt 13	31-163-00	D. Cregheur	6.3	4.50	4.50	202	0.33	4.50	4.50	319	0.25	0.25	4.50	138	0.27	0.27	-	0	0	0	-	0	0	0	0	659	659	
16NR	Pt 13	31-164-00	C. Mugas & K. Beardwood	0.8	1.20	1.20	54	0.09	1.20	1.20	85	0.07	0.07	1.20	37	0.07	0.07	-	0	0	0	-	0	0	0	0	176	176	
16NR	Pt 13	31-165-00	W. & K. Hawkins	2.5	2.25	2.25	101	0.17	2.25	2.25	160	0.13	0.13	5,600	2.25	69	11.23	-	0	0	0	-	0	0	0	5,600	330	5,930	
16NR	Pt 14	31-165-10	D. & T. Brewster	5.0	2.90	2.90	130	0.21	2.90	2.90	206	0.16	0.16	17,300	2.90	89	34.45	-	0	0	0	-	0	0	0	17,300	425	17,725	
16NR	Pt 14	31-165-15	A. & J. Natale	0.9	1.35	1.35	61	0.10	1.35	1.35	96	0.08	0.08	1.35	41	0.08	0.08	-	0	0	0	-	0	0	0	0	198	198	
16NR	Pt 14	31-165-17	A. & J. Natale	1.6	2.40	2.40	108	0.18	2.40	2.40	170	0.13	0.13	2.40	74	0.15	0.15	-	0	0	0	-	0	0	0	0	352	352	
16NR	Pt 14	31-166-00	H. & S. Dyck	1.7	2.55	2.55	114	0.19	2.55	2.55	181	0.14	0.14	2.55	78	0.15	0.15	-	0	0	0	-	0	0	0	0	373	373	
16NR	Pt 14	31-166-02	J. Brooks	0.4	0.60	0.60	27	0.04	0.60	0.60	43	0.03	0.03	0.60	18	0.04	0.04	-	0	0	0	-	0	0	0	0	88	88	
16NR	Pt 14	31-172-22	Town of Fort Erie	1.3	1.95	1.95	87	0.14	1.95	1.95	138	0.11	0.11	1.95	60	0.12	0.12	-	0	0	0	-	0	0	0	0	285	285	
16NR	Pt 14	31-172-24	A. & J. Natale	2.0	3.00	3.00	134	0.22	3.00	3.00	213	0.17	0.17	3.00	92	0.18	0.18	-	0	0	0	-	0	0	0	0	439	439	
15&16NR	Pts 13&14	31-996-00	C P Rail - Caso	5.8	8.70	8.70	390	0.64	16,000	8.70	617	12.99	12.99	2.55	78	0.15	0.15	-	0	0	0	-	0	0	0	16,000	1,085	17,085	
Sub-Total (Lands):				135.5	133.30	31,424	133.30	5,976	61.84	66,800	125.35	8,896	59.18	22,900	54.40	1,667	48.67	0	-	0	0	-	0	-	0	0	121,124	16,539	137,663
Roads																													
Point Abino Road				1.1	2.75	16,000	2.75	123	26.66	-	0	0	0	-	0	0	0	-	0	0	0	-	0	0	0	16,000	123	16,123	
Burger Road				1.6	4.00	4,000	4.00	179	0.30	16,000	4.00	284	12.73	-	0	0	0	-	0	0	0	-	0	0	0	16,000	463	16,463	
Special Assess. to Burger Road				0	0.00	-	0	0	0	25,235	-	0	19.73	-	0	0	0	-	0	0	0	-	0	0	0	25,235	0	25,235	
1/2 Holloway Bay Road				1.2	1.20	1,200	1.20	54	0.09	1,200	1.20	85	0.07	8,000	1.20	37	15.92	-	0	0	0	-	0	0	0	0	8,000	176	8,176
Fox Road				1.4	3.50	3,500	3.50	157	0.26	3,500	3.50	248	0.19	2.75	84	0.17	0.17	-	0	0	0	-	0	0	0	0	489	489	
Sub-Total (Roads):				5.3	11.45	16,000	11.45	513	27.31	41,235	8.70	617	32.72	8,000	3.95	121	16.09	0	-	0	0	0	-	0	0	0	65,235	1,251	66,486
Total Assessment for Town of Fort Erie:				140.8	144.75	47,424	144.75	6,489	89.15	108,035	134.05	9,513	91.9	30,900	58.35	1,788	64.76	0	-	0	0	0	-	0	0	0	186,359	17,790	204,149
City of Port Colborne (27-11-040-00) (Former Twp of Humberstone)																													
Lands																													
4	Pts 1&2	6-072-15	776542 Ont. Ltd.	19.0	15.55	15.55	697	1.15	15.55	1,103	0.86	0.86	15.55	476	0.94	0.94	2.70	124	0.2	2.70	24	0.03	0	0	0	2,424	2,424		
4	Pt 3	6-075-00	776542 Ont. Ltd.	14.2	11.70	11.70	524	0.87	11.70	830	0.65	0.65	11.70	358	0.71														

APPENDIX B - CALCULATION OF ASSESSMENTS FOR FUTURE MAINTENANCE

SCHIDL DRAIN

Town of Fort Erie and City of Port Colborne

				Interval 1				Interval 2				Interval 3				Interval 4				Interval 5				TOTAL					
				Sta. 0+000 to 0+777				Sta. 0+777 to 1+904				Sta. 1+904 to 2+478				Sta. 2+478 to 3+200				Sta. 3+200 to 3+541									
Total Cost Estimate:				7,800 (777m @ \$10/m)				11,300 (1127m @ \$10/m)				5,700 (574m @ \$10/m)				7,200 (722m @ \$10/m)				3,400 (341m @ \$10/m)				35,400					
Conc.	Lot	Roll No.	Owner	Total Affected (Ha)	Total Adjusted (Ha)	Benefit (\$)	Adjusted (Ha)	Outlet (\$)	%	Benefit (\$)	Adjusted (Ha)	Outlet (\$)	%	Benefit (\$)	Adjusted (Ha)	Outlet (\$)	%	Benefit (\$)	Adjusted (Ha)	Outlet (\$)	%	Benefit (\$)	Adjusted (Ha)	Outlet (\$)	%	Total Benefit	Total Outlet	TOTAL	
Town of Fort Erie (27-03-020-0) (Former Township of Bertie)																													
Lands																													
14NR	Pt 14	31-086-00	R. Singleton	1.70	0.85	310	0.85	16	4.18	-	0	0	0	-	0	0	0	-	0	0	0	0	-	0	0	0	310	16	326
14NR	Pt 14	31-087-00	J. Robertson & S. Cavey	2.10	1.05	310	1.05	20	4.23	-	0	0	0	-	0	0	0	-	0	0	0	-	0	0	0	310	20	330	
14NR	Pt 14	31-088-00	D. Merritt	1.90	0.95	200	0.95	18	2.79	-	0	0	0	-	0	0	0	-	0	0	0	-	0	0	0	200	18	218	
14NR	Pt 14	31-089-00	D. Merritt	1.90	0.95	190	0.95	18	2.67	-	0	0	0	-	0	0	0	-	0	0	0	-	0	0	0	190	18	208	
14NR	Pt 13	31-093-00	C. Wegelin	0.30	0.30	2	0.30	6	0.10	-	0	0	0	-	0	0	0	-	0	0	0	-	0	0	0	2	6	8	
14NR	Pt 14	31-094-00	R. Charron	2.80	2.70	560	2.70	51	7.83	-	0	0	0	-	0	0	0	-	0	0	0	-	0	0	0	560	51	611	
14NR	Pt 14	31-096-00	R. & D. Willick	2.30	1.15	-	1.15	22	0.28	-	0	0	0	-	0	0	0	-	0	0	0	-	0	0	0	0	22	22	
15NR	Pt 12	31-137-01	J. Mymryk	0.90	0.90	-	0.90	17	0.22	-	0	0	0	-	0	0	0	-	0	0	0	-	0	0	0	0	17	39	
15NR	Pts 13&14	31-140-00	Willoyd Ltd.	36.80	34.65	-	34.65	650	8.33	1,160	34.65	838	17.68	-	0	0	0	-	0	0	0	-	0	0	0	1,160	1,488	2,648	
15NR	Pt 14	31-141-00	H. Van Der Meer	6.00	6.00	-	6.00	113	1.45	1,080	6.00	145	10.84	-	0	0	0	-	0	0	0	-	0	0	0	1,080	258	1,338	
15NR	Pt 14	31-142-00	K. & S. Sider	1.80	2.70	-	2.70	51	0.65	-	2.70	65	0.58	-	0	0	0	-	0	0	0	-	0	0	0	0	116	116	
15NR	Pt 14	31-143-00	W. & S. Kikkert	1.80	2.70	-	2.70	51	0.65	-	2.70	65	0.58	-	0	0	0	-	0	0	0	-	0	0	0	0	116	116	
15NR	Pt 14	31-144-00	D. Dagesse & D. Holloway	1.80	2.70	-	2.70	51	0.65	-	2.70	65	0.58	-	0	0	0	-	0	0	0	-	0	0	0	0	116	116	
15NR	Pt 14	31-145-00	L. & A. Smith	1.80	2.70	-	2.70	51	0.65	-	2.70	65	0.58	-	0	0	0	-	0	0	0	-	0	0	0	0	116	116	
15NR	Pt 14	31-146-00	W. Yuan & G. Li	3.00	2.10	-	2.10	39	0.50	160	2.10	51	1.87	-	0	0	0	-	0	0	0	-	0	0	0	160	90	250	
15NR	Pt 14	31-147-00	C. Stackwood	2.30	3.45	-	3.45	65	0.83	170	3.45	83	2.24	-	0	0	0	-	0	0	0	-	0	0	0	170	148	318	
15NR	Pt 14	31-148-00	R. & A. Swinson	6.90	6.90	-	6.90	129	1.65	170	6.90	167	2.98	-	0	0	0	-	0	0	0	-	0	0	0	170	296	466	
16NR	Pt 11	31-160-04	P. Potts	2.50	1.25	-	1.25	23	0.29	-	1.25	30	0.27	-	0	0	0	-	0	0	0	-	0	0	0	0	70	70	
16NR	Pts 11&12	31-162-00	R. Brost & T. Chute	19.70	17.55	-	17.55	329	4.22	-	17.55	424	3.75	-	0	0	0	-	0	0	0	-	0	0	0	0	997	997	
16NR	Pt 13	31-162-01	P. & A. Brunet	8.90	10.35	-	10.35	194	2.49	-	10.35	250	2.21	-	0	0	0	-	0	0	0	-	0	0	0	0	588	588	
16NR	Pt 13	31-163-00	D. Cregheur	6.30	4.50	-	4.50	84	1.08	-	4.50	109	0.96	-	0	0	0	-	0	0	0	-	0	0	0	0	256	256	
16NR	Pt 13	31-164-00	C. Mugas & K. Beardwood	0.80	1.20	-	1.20	23	0.29	-	1.20	29	0.26	-	0	0	0	-	0	0	0	-	0	0	0	0	69	69	
16NR	Pt 13	31-165-00	W. & K. Hawkins	2.50	2.25	-	2.25	42	0.54	-	2.25	54	0.48	610	2.25	31	11.25	-	0	0	0	-	0	0	0	610	127	737	
16NR	Pt 14	31-165-10	D. & T. Brewster	5.00	2.90	-	2.90	54	0.69	-	2.90	70	0.62	1,290	2.90	40	23.33	-	0	0	0	-	0	0	0	1,290	164	1,454	
16NR	Pt 14	31-165-15	A. & J. Natale	0.90	1.35	-	1.35	25	0.32	-	1.35	33	0.29	-	0	0	0	-	0	0	0	-	0	0	0	0	77	77	
16NR	Pt 14	31-165-17	A. & J. Natale	1.60	2.40	-	2.40	45	0.58	-	2.40	58	0.51	-	0	0	0	-	0	0	0	-	0	0	0	0	136	136	
16NR	Pt 14	31-166-00	H. & S. Dyck	1.70	2.55	-	2.55	48	0.62	-	2.55	62	0.55	-	0	0	0	-	0	0	0	-	0	0	0	0	146	146	
16NR	Pt 14	31-166-02	J. Brooks	0.40	0.60	-	0.60	11	0.14	-	0.60	15	0.13	-	0	0	0	-	0	0	0	-	0	0	0	0	34	34	
16NR	Pt 14	31-172-22	Town of Fort Erie	1.30	1.95	-	1.95	37	0.47	-	1.95	47	0.42	-	0	0	0	-	0	0	0	-	0	0	0	0	111	111	
16NR	Pt 14	31-172-24	A. & J. Natale	2.00	3.00	-	3.00	56	0.72	-	3.00	73	0.65	-	0	0	0	-	0	0	0	-	0	0	0	0	171	171	
15&16NR	Pts 13&14	31-996-00	C.P.Rail - Caso	5.80	8.70	-	8.70	163	2.09	890	8.70	210	9.73	-	2.55	36	0.63	-	0	0	0	-	0	0	0	890	409	1,299	
Sub-Total (Lands):				135.50	133.30	1,572	133.30	2,502	52.20	3,630	125.35	3,030	58.95	1,900	54.40	757	46.62	0	-	0	-	0	-	0	-	0	7,102	6,289	13,391
Roads																													
	Point Abino Road		Town of Fort Erie	1.10	2.75	770	2.75	52	10.54	-	-	0	0	-	-	0	0	-	-	0	0	-	-	0	0	770	52	822	
	Burger Road		Town of Fort Erie	1.60	4.00	890	4.00	75	0.96	890	4.00	97	8.73	-	-	0	0	-	-	0	0	-	-	0	0	890	172	1,062	
	1/2 Holloway Bay Road		Town of Fort Erie	1.20	1.20	-	1.20	23	0.29	-	1.20	29	0.26	475	1.20	17	8.63	-	-	0	0	-	-	0	0	475	69	544	
	Fox Road		Town of Fort Erie	1.40	3.50	-	3.50	66	0.85	-	3.50	85	0.75	-	2.75	38	0.67	-	-	0	0	-	-	0	0	0	0	189	189
Sub-Total (Roads):				5.30	11.45	770	11.45	216	12.64	890	8.70	211	9.74	475	3.95	55	9.3	0	-	0	-	0	-	0	-	0	2,135	482	2,617
Total Assessment for Town of Fort Erie:				140.80	144.75	2,342	144.75	2,718	64.84	4,520	134.05	3,241	68.69	2,375	58.35	812	55.92	0	-	0	-	0	-	0	-	0	9,237	6,771	16,008
City of Port Colborne (27-11-040-00) (Former Twp of Humberstone)																													
Lands																													
4	Pts 1&2	6-072-15	776542 Ont. Ltd.	19.00	15.55	-	15.55	292	3.74	-	15.55	376	3.33	-	15.55	217	3.81	2.70	60	0.83	-	2.70	86	2.53	0	1,031	1,031		
4	Pt 3	6-075-00	776542 Ont. Ltd.	14.20	11.70	-	11.70	219	2.81	-	11.70	283	2.5	-	11.70	163	2.86	11.70	258	3.58	270	11.70	374	18.94	270	1,297	1,567		
4	Pt 4	6-078-00	D. & S. Anderson	10.80	6.30	-	6.30	118	1.51	-	6.30	152	1.35	-	6.30	88	1.54	6.30	139	1.93	-	6.30	201	5.91	0	698	698		
5	Pts 1&2	6-113-00	776542 Ont. Ltd.	46.10	41.10	-	41.10	771	9.88	-	41.10	994	8.8	2,160	41.10	572	10.04	41.10	906	42.58	520	0.60	19	15.85	2,680	3,262	5,942		
5	Pts 1&2	6-114-00	S. & J. Hwang	13.90	13.50	-	13.50	253	3.24	-	13.50	326	2.88	-	13.50	188	3.3	13.50	298	4.14	-	-	0	0	0	0	1,065	1,065	
5	Pts 3&4	6-119-00	Loeffen Farms Ltd.	1.60	0.80	-	0.80	15	0.19	-	0.80	19	0.17	-	0.80	11	0.19	0.80	18	0.25	-	-	0	0	0	0	63	63	
5	Pts 3&4	6-120-00	2144894 Ont Ltd	1.50	0.75	-	0.75	14	0.18	-	0.75	18	0.16	-	0.75	10	0.18	0.75											

GENERAL CONDITIONS**TABLE OF CONTENTS**

200.1	SCOPE	1
200.2	ORDER OF PRECEDENCE	1
200.3	MUNICIPALITY	1
200.4	TENDERS	1
200.5	EXAMINATION OF SITE, PLANS AND SPECIFICATIONS	1
200.6	COMMENCEMENT AND COMPLETION OF WORK	2
200.7	NOTICES RE COMMENCEMENT OF WORK	2
200.8	PERMITS, NOTICES, LAWS AND RULES	2
200.9	HEALTH AND SAFETY	2
200.10	LIMITATIONS OF OPERATIONS	2
200.11	SUPERVISION	3
200.12	CHARACTER AND EMPLOYMENT OF WORKERS	3
200.13	SUB-CONTRACTORS	3
200.14	PAYMENT	3
200.15	TERMINATION OF CONTRACT BY THE MUNICIPALITY	3
200.16	LIQUIDATED DAMAGES	4
200.17	CONTRACTOR'S LIABILITY	4
200.18	LIABILITY INSURANCE	5
200.19	LOSSES DUE TO ACTS OF NATURE, ETC.	5

200 GENERAL CONDITIONS**200.1 SCOPE**

The work to be done under this contract consists of supplying all labour, equipment and materials to construct the drainage work as outlined in the Instructions to Tenderers, the Form of Tender and Agreement, the Schedule of Tender Prices, the Drawings, the General Conditions, Special Provisions and the Standard Specifications.

200.2 ORDER OF PRECEDENCE

In case of any inconsistency or conflict between the drawings and specifications, the following order of precedence shall apply: Addenda, Form of Tender and Agreement, Schedule of Tender Prices, Special Provisions, Contract Drawings, Standard Specifications, General Conditions.

200.3 MUNICIPALITY

Municipality refers to a municipal corporation in the Province of Ontario. Where reference to Township, County, Region, Town, City or Owner appears it shall be deemed to be the same as the word Municipality. Where reference to owner appears in the specifications it is usually in reference to the owner of the property on which the drain is being constructed.

200.4 TENDERS

Tenders are to be submitted on a lump sum basis for the complete works or a portion thereof, as instructed by the Municipality. The Schedule of Tender Prices must be completed and submitted with the Form of Tender and Agreement even though the Contract will be a lump sum. As outlined in the Instructions to Tenders a deposit in the form of a certified cheque, bank draft, bonding or irrevocable letter of credit must accompany each tender as a guarantee of good faith. The deposit shall name the Municipality as the payee. All deposits, except that of the Tenderer to whom the work is awarded, will be returned within 10 days of the time the contract is awarded. The certified cheque of the Tenderer awarded the work will be retained as Contract Security and returned with the Completion Certificate for the work. A Performance Bond may also be required to ensure maintenance of the work for a period of one year after the date of the Completion Certificate.

200.5 EXAMINATION OF SITE, PLANS AND SPECIFICATIONS

Prior to the submission of the Tender, the Tenderer must examine the premises and site to compare them with the Drawings and Specifications in order to be satisfied with the existing conditions and the extent of the work to be done. The Tenderer must ensure that the meaning and intent of the drawings, estimated quantities and specifications is clearly understood before submission of the Tender. No allowances shall be made on behalf of the Contractor by reason of any error made in the preparation of the tender submission.

Any estimates of quantities shown or indicated on the drawings or elsewhere in the tender document are provided for the convenience of the Tenderer. The Tenderer should check the estimate of quantities for accuracy. Any use made of the estimated quantities by the Tenderer in calculating the tendered amounts is done at the Tenderers risk.

200.6 COMMENCEMENT AND COMPLETION OF WORK

The work must commence immediately after the Tenderer is notified of the contract award or at a later date, if set out as a condition in the Form of Tender and Agreement. If weather and ground conditions are unsuitable, work may be started at a later date from either of the above two dates if such delay is approved by the Engineer. The Contractor shall provide a minimum of 48 hours advance notice to the Engineer and the Municipality before commencement of any work. The work must proceed in such manner as to ensure its completion at the earliest possible date consistent with first class workmanship and within the time limit set out in the tender/contract document. Failure to commence or complete the work as set out in the tender/contract document may result in a forfeiture of all or part of the Contract Security if the Engineer deems that damages have been sustained to the Municipality or to any landowner because of the non-commencement or non-completion of the contract as awarded and that the failure to meet the specified dates has been the fault of the Contractor.

200.7 NOTICES RE COMMENCEMENT OF WORK

If the Contractor leaves the job site for a period of time after initiation of work, a minimum of 48 hours advance notice shall be given to the Engineer and the Municipality before commencement of any further work. If any work is commenced without the advance notice the Contractor shall be fully responsible for all such work undertaken prior to such notification and shall make good any works or materials judged to be inadequate or constructed in any manner that may have been subject to alteration if made known to the Engineer prior to commencement of construction.

200.8 PERMITS, NOTICES, LAWS AND RULES

The Contractor shall apply and pay for all necessary permits or licenses required for the execution of the work. This shall not include the obtaining of permanent easements or rights or servitude. The Contractor shall give all necessary notices and pay all fees required by the law and comply with all laws, ordinances, rules and regulations relating to the work and to the preservation of the public's health and safety and if the specifications and drawings are at variance therewith, any resulting additional expense incurred by the Contractor shall constitute an addition to the contract price.

200.9 HEALTH AND SAFETY

Contractor must comply with the Occupational Health and Safety Act (OHSA) and the associated Regulations for Construction Projects. Contractor will also follow any site-specific safety and training requirements of the Municipality, agencies, utility companies or other authorities.

Communication about site-specific hazards and safety requirements shall occur at the pre-construction meeting. If no pre-construction meeting is conducted, Contractor will communicate site-specific hazards and safety requirements before beginning work.

Contractor shall immediately report any workplace incidents, near misses, injuries and occupational illnesses to the Engineer.

200.10 LIMITATIONS OF OPERATIONS

Except for such work as may be required by the Engineer to maintain the works in a safe and satisfactory condition, the Contractor shall not carry out operations under the contract on Sundays or Statutory Holidays without permission in writing from the Engineer. The Engineer may direct in writing to the Contractor to cease or limit operations under the contract on any day or days if the operations are of such a nature, or if the work is so located, or if the traffic is of such a volume, that the Engineer deems it necessary or expedient to do so.

200.11 SUPERVISION

The Contractor shall provide constant supervision of the construction work and shall keep a competent foreman in charge at the site.

200.12 CHARACTER AND EMPLOYMENT OF WORKERS

The Contractor shall employ only orderly, competent and skillful workers to do the work and shall give preference to available qualified residents in the area of the contract. Whenever the Engineer informs the Contractor in writing that any workers are, in the opinion of the Engineer, disorderly, incompetent, or breaking the law, such workers shall be discharged from the job site and shall not again be employed on the job site without the written consent of the Engineer.

200.13 SUB-CONTRACTORS

If the Municipality so directs, the Contractor shall not sublet the whole or any part of this contract without the approval of the Engineer.

200.14 PAYMENT

Progress payments in cash equal to about 90% of the value of the work done and materials incorporated in the work will be made to the Contractor monthly. If directed by the Engineer the Contractor may be required to provide a written request for the progress payment amount. An additional 7% will be paid 45 days after the date of the Completion Certificate by the Engineer and 3% of the contract price may be reserved by the Municipality as a maintenance holdback for one year from the date of the Completion Certificate.

The holdbacks noted above may be increased by the Municipality if, in the written opinion of the Engineer, particular conditions of the contract require such greater holdback.

After the completion of the work any part of maintenance holdback may be used to correct defects from faulty construction and/or materials provided that notice shall first be given by the Engineer in writing to the Contractor stating that the Contractor has seven (7) days in which to remedy the defect in construction and/or materials.

200.15 TERMINATION OF CONTRACT BY THE MUNICIPALITY

Termination of the contract by the Municipality may be considered if the Contractor:

1. should be adjudged bankrupt or make a general assignment for the benefit of creditors or if a receiver should be appointed on account of insolvency;
2. should refuse or fail to supply enough properly skilled workmen or proper materials after having received seven (7) days' notice in writing from the Engineer to supply such additional workmen or materials in order to commence or complete the works;
3. should fail to make prompt payment to sub-contractors or for materials or labour;
4. should persistently disregard laws, ordinances, or instructions from the Engineer, or otherwise be guilty of a substantial violation of the provisions of the contract;

then the Municipality, upon Certificate of the Engineer that sufficient cause exists to justify such action, may without prejudice to any other right or remedy, give written notice to the Contractor to terminate the employment of the Contractor and take possession of the premises, and of all materials, tools and appliances thereon, and may finish the work by whatever method the Municipality may deem expedient, but without undue delay or expense. In such case, the Contractor shall not be entitled to receive any further payment until the work is finished. If the unpaid balance of the contract price will exceed the expense of finishing the work including compensation to the Engineer for additional

services and including other damages of every name and nature, such excess shall be paid to the Contractor. If such expense will exceed such unpaid balance including the Contract Security, the Contractor shall pay the difference to the Municipality. The expense incurred by the Municipality, as herein provided, shall be certified by the Engineer. If the contract is terminated by the Municipality due to the Contractor's failure to properly commence the works, the Contractor shall forfeit the Contract Security and furthermore shall pay to the Municipality an amount to cover the increased costs, if any, associated with a new tender for the contract being terminated.

If any unpaid balance and the Contract Security do not equal the monies owed by the Contractor upon the termination of the contract, the Municipality may also charge such expenses against any money which is or may thereafter be due to the Contractor from the Municipality.

200.16 LIQUIDATED DAMAGES

It is agreed by the parties to the Contract that in case all the work called for under the Contract is not finished or complete within the period of time as set forth in the Tender/Contract Document, damage will be sustained by the Municipality. It is understood by the parties that it will be impracticable and extremely difficult to ascertain and determine the actual damage which the Municipality will sustain in the event of and by reason of such delay. The parties hereto agree that the Contractor will pay to the Municipality a sum as set out in the Form of Tender and Agreement for liquidated damages for each and every calendar day delay, including Saturdays, Sundays and Statutory Holidays, in finishing the work in excess of the number of working days prescribed. It is agreed that the liquidated damages amount is an estimate of the actual damage to the Municipality which will accrue during the period in excess of the prescribed number of working days.

The Municipality may deduct any amount due under this section from any monies that may be due or payable to the Contractor on any account whatsoever. The liquidated damages payable under this section are in addition to and without prejudice to any other remedy, action or other alternative that may be available to the Municipality.

The Contractor shall not be assessed with liquidated damages for any delay caused by acts of nature, or of the Public Enemy, Acts of the Province or of any Foreign State, Fire, Flood, Epidemics, Quarantine Restrictions, Embargoes or any delays of Sub-Contractors due to such causes.

If the time available for the completion of the work is increased or decreased by reason of alterations or changes made under the provisions of the Contract, the number of working days shall be increased or decreased as determined by the Engineer.

If the Form of Tender and Agreement does not show an amount for Liquidated Damages then Liquidated Damages do not apply for this contract.

200.17 CONTRACTOR'S LIABILITY

The Contractor and all workers, agents or any party under the Contractor's control, including Sub-Contractors, shall use due care that no person or property is injured and that no rights are infringed during the construction work outlined in the contract. The Contractor shall be solely responsible for all damages by whomsoever claimable in respect of any injury to persons or to lands, buildings, structures, fences, livestock, trees, crops, roadways, ditches, drains and watercourses, whether natural or artificial, or property of whatever description and in respect of any infringement of any right, privilege or easement wherever occasioned in the carrying on of the work or any part thereof, or by any neglect, misfeasance or non-feasance on the Contractor's part or on the part of any workers, agents or parties under the Contractor's control including Sub-Contractors, and shall bear the full cost thereof. The Contractor shall be fully responsible to make such temporary provisions as may be necessary to ensure the avoidance of any such damage, injury or infringement and to prevent the interruption of or danger or menace to the traffic in any railway or any public or private road entrance or sidewalk and to secure to all persons and corporations the uninterrupted enjoyment of all their

rights, in and during the performance of the work. The Contractor shall indemnify and save harmless the Municipality and the Engineer from and against all claims, demands, losses, costs, damages, actions, suits or other proceedings by whomsoever made, brought or prosecuted in any manner based upon, occasioned by, or attributed to any such damage, injury or infringement.

Wherever any work is of such an extent and nature that it must necessarily be confined to particular areas of a roadway, a working area, or private property, the Contractor shall use reasonable care not to damage or deface the remaining portions of the property, and if any damage is occasioned as a result of the Contractor's operations, it shall be rectified by and at the expense of the Contractor, to the satisfaction of the Engineer. Notwithstanding the indemnity provisions contained in this section, where in the opinion of the Engineer the Contractor has failed to rectify any damage, injury or infringement or has failed to adequately compensate any person for any damage, injury or infringement for which the Contractor is responsible under the contract, the Engineer, following notice in writing to the Contractor of an intention so to do, may withhold payment of any monies due the Contractor under this or any other contract until the Contractor has rectified such damage, injury or infringement or has paid adequate compensation for such damage, injury or infringement, provided however, that the Municipality will not withhold such monies where in the opinion of the Engineer there are reasonable grounds upon which the Contractor denies liability for such damage, injury or infringement and the Contractor has given the claimant a reasonable time in which to establish the validity of the claim, and provided further that the amount withheld under this section shall not exceed the amount of such claims against the Contractor.

Where the Contractor uses privately owned lands for pits or waste disposal areas, the Contractor shall comply with applicable laws and provide the Engineer with a release signed by or on behalf of the owner of each pit or waste disposal area used by the Contractor. If the said release is not obtained, then sufficient monies will be withheld from the Contractor except, however, where the owner's signature is withheld solely on the basis of damage, injury, or infringement it will be dealt with as provided elsewhere in this subsection.

Nothing herein contained shall be construed as in any way restricting or limiting the liability of the Contractor under the laws of the country, province or locality in which the work is being done. Neither the Completion Certificate nor final payment thereunder, nor any provision in the Contract Document shall relieve the Contractor from this liability.

200.18 LIABILITY INSURANCE

The Contractor shall take out and keep in force until the date of acceptance of the entire work by the Engineer, a comprehensive policy of public liability and property damage insurance providing insurance coverage of at least \$3,000,000 for each and every accident, exclusive of interest and cost, against loss or damage resulting from bodily injury to or death of one or more persons and loss of or damage to property and such policy shall where, and as requested by the Municipality, name the Municipality and the Engineer as an additional insured thereunder and shall protect the Municipality against all claims for all damage or injury including death to any person or persons and for damage to any property of the Municipality or any other public or private property resulting from or arising out of any act or omission on part of the Contractor or any of his servants or agents during the execution of the Contract.

200.19 LOSSES DUE TO ACTS OF NATURE, ETC.

All damage, loss, expense and delay incurred or experienced by the Contractor in the prosecution of the work, by reason of unanticipated difficulties, bad weather, strikes, wars, acts of nature, or other mischances, shall be borne by the Contractor and shall not be the subject of a claim for additional compensation.

TABLE OF CONTENTS

400.1	ABBREVIATIONS.....	1
400.2	PRE CONSTRUCTION MEETING	1
400.3	COLD WEATHER.....	1
400.4	WORKING AREA	1
400.5	ACCESS.....	1
400.6	ACCESS TO PROPERTIES ADJOINING THE WORK	2
400.7	DRAINAGE SUPERINTENDENT	2
400.8	ALTERATIONS TO WORK.....	2
400.9	ERRORS AND UNUSUAL CONDITIONS	2
400.10	TESTS	2
400.11	BENCHMARKS AND STAKES.....	3
400.12	OPENING UP OF FINISHED WORK	3
400.13	FINAL INSPECTION.....	3
400.14	WARRANTY	3
400.15	MATERIALS	4
400.16	RIPRAP	5
400.17	GEOTEXTILE	5
400.18	DISPOSAL OF MATERIALS	5
400.19	NOTIFICATION OF RAILROADS, ROAD AUTHORITIES AND UTILITIES	5
400.20	WORKING IN ROAD ALLOWANCES	6
400.21	LOCATIONS OF EXISTING UTILITIES.....	6
400.22	LANEWAYS.....	7
400.23	EXISTING CROSSING CLEANOUT	7
400.24	FENCES.....	7
400.25	LIVESTOCK	8
400.26	STANDING CROPS	8
400.27	CLEARING VEGETATION	8
400.28	ROCK REMOVAL.....	9
400.29	SEEDING	10
400.30	EROSION CONTROL BLANKETS.....	11
400.31	SEDIMENT CONTROL.....	11
400.32	GRASSED WATERWAYS AND OVERFLOW SWALES.....	12
400.33	BUFFER STRIPS	13
400.34	MAINTENANCE CORRIDOR	13
400.35	POLLUTION	13
400.36	SPECIES AT RISK	13

400 STANDARD SPECIFICATIONS FOR CONSTRUCTION OF DRAINS

400.1 ABBREVIATIONS

- i) M.T.O. means the Ministry of Transportation of Ontario.
- ii) A.S.T.M. means the American Society for Testing Materials.
- iii) C.S.A. means the Canadian Standard Association.
- iv) O.P.S.D. means Ontario Provincial Standard Drawings
- v) O.P.S.S. means Ontario Provincial Standard Specifications
- vi) DFO means Fisheries and Oceans Canada
- vii) MNRF means Ministry of Natural Resources and Forestry
- viii) MOECC means Ministry of Environment and Climate Change

400.2 PRE CONSTRUCTION MEETING

The Contractor should arrange a pre-construction meeting with the Engineer, Municipality, affected landowners prior to commencement of construction.

If there is no pre-construction meeting or if a landowner is not present at the pre-construction meeting, the following shall apply. The drain is to be walked by the Contractor and each landowner prior to construction to ensure that both agree on the work to be done. Any difference of opinion shall be referred to the Engineer for decision. If the landowner is not contacted for such review, they are to advise the Engineer and/or Municipality.

400.3 COLD WEATHER

When working in cold weather is approved by the Engineer, the Contractor shall provide suitable means for heating and protection. All work completed in cold weather conditions shall be to the satisfaction of the Engineer and any additional cost to remedy unsatisfactory work, or protect the work shall be borne by the Contractor. All backfilling operations shall be done as soon as possible to avoid backfilling with ground containing frozen particles. The Contractor will assume all responsibility for damages to any tile drains and for settlements or bank slippages that may result from work in cold weather.

400.4 WORKING AREA

Where any part of the drain is on a road allowance, the road allowance shall be the working area. For a closed drain the working area shall be a 10 metre width on either side of the trench or any combination not exceeding 20 metres. A 10m x 10m working area shall exist around any catchbasin, junction box or access point. For an open drain the working area shall be 17 metres on the side for leveling and 3 metres on the opposite side. A 10m working area shall exist for any overflow swale or grassed waterway. If any part of the drain is close to a property line then the fence line shall be one of the limits of the work area. Reduced or increased working areas will be described in detail on the Drawings.

400.5 ACCESS

The Contractor shall have access to the drain by entering the working area directly from road allowances or along access routes shown on the Drawings. All specifications governing fences, livestock and crops during drain construction apply to access routes. No other access routes shall be used unless first approved by the Engineer and the affected landowner. The Contractor shall contact each landowner prior to using the designated access routes. Contractor shall make good any damages caused by using the designated access routes.

400.6 ACCESS TO PROPERTIES ADJOINING THE WORK

The Contractor shall provide at all times and at no additional cost, adequate pedestrian access to private homes and commercial establishments unless otherwise authorized by the Engineer. Where interruptions to access have been authorized by the Engineer, reasonable notice shall be given by the Contractor to the affected landowners and such interruptions shall be arranged to minimize interference to those affected.

400.7 DRAINAGE SUPERINTENDENT

Where a Drainage Superintendent (Superintendent) is appointed by the Municipality, the Engineer may designate the Superintendent to act as the Engineer's representative. If so designated, the Superintendent will have the power to inspect and direct the execution of the work.

Any instructions given by the Superintendent which change the proposed work or with which the Contractor does not agree shall be referred to the Engineer for final decision.

400.8 ALTERATIONS TO WORK

The Engineer shall have the power to make alterations, additions and/or deletions in the work as shown or described in the Drawings or Specifications and the Contractor shall proceed to implement such changes without delay. Alterations ordered by the Engineer shall in no way render the contract void.

If a landowner desires deviations from the work described on the Drawings, the landowner shall submit a written request to the Engineer, at least 48 hours in advance of the work in question.

In every such case, the contract amount shall be increased or decreased as required according to a fair evaluation of the work completed. Where such changes involve additional work similar to items in the contract, the price for additional work shall be determined after consideration is given to the tendered price for similar items.

In no case shall the Contractor commence work considered to be extra work without the Engineer's approval. Payment for extra work is contingent on receipt of documentation to the satisfaction of the Engineer. Refer to the Extra Work Summary included in the Special Provisions.

400.9 ERRORS AND UNUSUAL CONDITIONS

The Contractor shall notify the Engineer immediately of any error or unusual conditions which may be found. Any attempt by the Contractor to correct the error without notice shall be done at the Contractor's risk. Any additional cost incurred by the Contractor to remedy an error or unusual condition without notice shall be borne by the Contractor. The Engineer shall direct the alteration necessary to correct errors or unusual conditions. The contract amount shall be adjusted in accordance with a fair evaluation of documentation for the work added, deleted or adjusted.

400.10 TESTS

The Engineer reserves the right to subject any materials to a competent testing laboratory for compliance with the standard. If any materials supplied by the Contractor are determined to be inadequate to meet the applicable standards, the Contractor shall bear full responsibility to remove and/or replace all such inadequate materials with materials capable of meeting the standards.

The cost of testing the materials supplied by the Contractor shall be borne by the Contractor.

400.11 BENCHMARKS AND STAKES

Prior to construction, the Engineer will confirm the benchmarks. The Contractor shall be held liable for the cost of replacing any benchmarks destroyed during construction.

If the Engineer provides layout stakes, the Contractor shall be held liable for the cost of replacing any layout stakes destroyed during construction.

Where property bars are shown on the Drawings, they are to be protected and if damaged by the Contractor, they will be reinstated by an Ontario Land Surveyor at the expense of the Contractor. Where property bars not shown on the Drawings are damaged, they will be reinstated by an Ontario Land Surveyor at the expense of the project.

400.12 OPENING UP OF FINISHED WORK

If ordered by the Engineer, the Contractor shall make such openings in the work as are needed to re-examine the work, and shall forthwith make the work good again. Should the Engineer find the work so opened up to be faulty in any respect, the whole of the expense of opening, inspecting and making the work good shall be borne by the Contractor. Should the Engineer find the work opened up to be in an acceptable condition the Contractor shall be paid for the expense of opening and making the work good, unless the Contractor has been obligated by any specification or by the direction of the Engineer to leave the work open for the Engineer's inspection.

400.13 FINAL INSPECTION

Final inspection by the Engineer will be made within twenty (20) days after receiving notice in writing from the Contractor that work is complete, or as soon thereafter as weather conditions permit. All the work included in the contract must at the time of final inspection have the full dimensions and cross-sections.

Prior to commencing the final inspection an on-site meeting may be held by the Engineer and landowners directly affected by the construction of the drain. The Contractor will attend this meeting upon notice by the Engineer.

If there is no on-site meeting with the Engineer and landowners, the Contractor shall obtain from each landowner a written statement indicating that the work has been performed to the owner's satisfaction. If the Contractor is unable to obtain a written statement from the landowner, the Engineer will determine if further work is required prior to issuing the Completion Certificate.

400.14 WARRANTY

There shall be a one-year warranty period on all completed work. The warranty period will commence on the date of the Completion Certificate.

When directed by the Engineer, the Contractor shall repair and make good any deficiencies in the work that may appear during the warranty period.

Before the work shall be finally accepted by the Municipality, the Contractor shall complete all work as directed by the Engineer and remove all debris and surplus materials and leave the work neat and presentable.

400.15 MATERIALS

400.15.1 Concrete Drain Tile

Concrete drain tile shall conform to the requirements of the most recent ASTM C412 specifications for heavy duty extra quality, unless a stronger concrete tile is required by the Special Provisions or Drawings. All tile furnished shall be subject to the approval of the Engineer.

The minimum nominal lengths of the tile shall be 750mm for 150 to 350mm diameter tile and 1200mm for 400 to 900mm diameter tile.

All tile should be of good quality, free from distortions and cracks and shall meet the standards specified. The ends should be smooth and free from cracks or checks. All rejected tile are to be immediately removed from the site.

Granular backfill, where required, shall consist of approved sand or gravel having no particles retained on a screen having 50mm square openings.

Earth backfill shall consist of approved material having no large lumps or boulders.

400.15.2 Corrugated Plastic Tubing

Corrugated plastic tubing shall conform to the *Land Improvement Contractors of Ontario Standard Specification for Corrugated Plastic Drainage Tubing, 2006*. Type of material (solid or perforated) and need for filter sock will be specified on the Drawings or in the description of the work in the Special Provisions. Filter sock where specified shall be a standard synthetic filter material as provided by a recognized plastic tubing manufacturer unless noted differently on the contract drawings or elsewhere in the contract document. Protect coils of plastic tubing from damage and deformation.

400.15.3 Corrugated Steel Pipe

Corrugated Steel Pipe (CSP) shall be according to OPSS 1801 (CSA G401). Unless stated otherwise in the Special Provisions the pipe shall be:

- galvanized
- helical corrugation with lock seam and re-rolled annular ends
- 68mm x 13mm corrugation profile for diameters up to 1200mm
- 125mm x 25mm corrugation profile for diameters 1200mm and larger
- minimum wall thickness of 1.6mm for diameters up to 500mm
- minimum wall thickness of 2.0mm for diameters 600mm and larger
- joined using standard couplers matching the pipe diameter and material

Other coatings that may be specified include aluminized Type 2 or polymer. Polymer coating shall be a 254mm polymer film laminated to both sides of the pipe.

400.15.4 Plastic Pipe

Plastic Pipe shall be a high density polyethylene (HDPE) double wall corrugated pipe with smooth inner wall, solid with no perforations in accordance with OPSS 1840.

A minimum stiffness of 320 KPa at 5% deflection

The pipe shall be joined with snap-on or split couplers.

400.15.5 Concrete Sewer Pipe

Concrete sewer pipe shall be in accordance with OPSS 1820.

Non-reinforced concrete sewer pipe shall be used for pipe 375mm in diameter and smaller and reinforced concrete sewer pipe shall be used for pipe over 375mm.

Classes shall be as shown on the Contract Drawings or as described in the Form of Tender.

All new concrete sewer pipe shall have rubber-type gasket joints.

Where concrete sewer pipe "seconds" are specified, the pipe should exhibit no damage or cracks on the barrel section and shall be capable of satisfying the crushing strength requirements of OPSS 1820. The pipe may contain cracks or chips in the bell or spigot which prevent the use of rubber gaskets but the joints must be protected with filter cloth.

400.16 RIPRAP

All riprap is to be placed on a geotextile underlay (Terrafix 360R or equal) unless directed otherwise in the specific construction notes. The riprap is to be graded heavy angular stone (quarry stone is recommended) with particles averaging in size from 225mm to 300mm and is to be placed at 300mm thickness. Fine particles may be included to fill voids. Along upstream edges of riprap, where surface water will enter, underlay is to extend a minimum of 300mm upstream from riprap and then be keyed down a minimum of 300mm. Wherever riprap is placed, the area is to be over-dug so that finished top of riprap is at design cross-section, at design elevation or flush with existing ground.

400.17 GEOTEXTILE

To be non-woven fabric that is rot proof, non-biodegradable, chemically resistant to acidic or alkaline soils and is dimensionally stable under different hydraulic conditions. The filter fabric is to be a material whose primary function is to act as a highly permeable, non-clogging soil separator for fine soils (Terrafix 360R or equal). Contractor is to avail himself of manufacturer's recommendations for cutting, installation and precautions necessary to avoid damage to fabric. Other approved equals will be considered by the Engineer prior to construction.

400.18 DISPOSAL OF MATERIALS

The Contractor shall remove all surplus materials from the job site at the end of the project. The Contractor shall locate the disposal site for all materials to be disposed of. Disposal of materials shall comply with applicable regulations.

400.19 NOTIFICATION OF RAILROADS, ROAD AUTHORITIES AND UTILITIES

Contractor will notify any Railroad, Road Authority or Utility at least 48 hours in advance regarding work to be performed on their property or affecting their infrastructure. The notice will be in writing and is exclusive of Saturdays, Sundays and Holidays.

A utility includes any entity supplying the general public with necessities or conveniences.

400.20 WORKING IN ROAD ALLOWANCES

400.20.1 General

Work within public road allowances shall be done in accordance with the Ontario Traffic Manual Book 7, latest edition.

400.20.2 Road Crossings

If no specific detail is provided for road crossings on the drawings or in the specifications the following shall apply:

- A Road Authority will supply no labour, equipment or materials for the construction of the road crossing.
- Contractor will not commence road crossing work until any required permits have been obtained. The Engineer may apply for any required permits prior to construction.
- Contractor will notify the Road Authority at least 72 hours in advance of any construction in the road allowance.
- Road crossings may be made with an open cut unless otherwise noted.
- Exact location of crossing shall be verified with the Road Authority and the Engineer.
- Pipe shall be placed on a minimum 150mm depth of Granular A shaped for the pipe.
- Pipe backfill shall be compacted Granular A and extend 300mm above the top of the pipe.
- Trench shall be backfilled with acceptable native material for the base width of the road bed.
- The material shall be placed in lifts not exceeding 300mm in depth and shall be thoroughly compacted with an approved mechanical vibrating compactor.
- Top 600mm of the road bed backfill shall consist of 450mm Granular B and 150mm of Granular A placed in lifts and fully compacted.
- Any surplus excavated material within the road allowance may be spread on the right-of-way with consent of the Road Superintendent otherwise the surplus material shall be hauled away.
- Existing asphalt or concrete pavement or surface treatment shall be replaced by the Contractor to the satisfaction of the Engineer and Road Authority.
- Contractor shall be responsible for correcting any backfill settlement during construction and during the warranty period. Upon approval of the road authority, surplus gravel shall be stockpiled near gravel road crossings to provide backfill for future trench settlement.
- All road crossings shall meet the approval of the Road Authority.
- If any road crossing is not left in a safe manner at the end of the working day barricades and warning signs shall be erected to guarantee the safety of the travelling public.
- If the Engineer deems a road to surface to have been damaged by the construction of a drain, either across or along the road, the Engineer may direct the Contractor to restore the road surface to existing or better condition at no additional cost.

400.20.3 Maintenance of Traffic

Unless directed otherwise on the drawings or in the specifications the Contractor shall keep the road open to traffic at all times. The Contractor shall provide suitable warning signs and/or flagging to the satisfaction of the Road Authority to notify of the construction work.

If a detour is required, the Contractor shall submit a proposal as to the details of the detour for approval by the Road Authority. If necessary to close the road to through traffic, the Contractor shall provide for and adequately sign the detour route. Contractor shall undertake all notifications required for a road closure in consultation with the Municipality.

400.21 LOCATIONS OF EXISTING UTILITIES

The position of pole lines, conduits, watermains, sewers and other underground and overhead utilities are not necessarily shown on the Contract Drawings, and, where shown, the accuracy of the position

of such utilities and structures is not guaranteed. Before starting work, the Contractor shall have all utilities located in accordance with the Ontario Underground Infrastructure Notification System Act.

All utilities shall be exposed to the satisfaction of the utility company to verify that the construction proposed will not conflict with the utility structure. Additional payment will be allowed for relocation of utilities if conflicts should occur.

The Contractor is responsible for protecting all located and exposed utilities from damage during construction. The Contractor shall assume liability for damage caused to all properly located utilities.

400.22 LANEWAYS

If no specific detail is provided for laneway crossings on the Drawings or in the Specifications the following shall apply:

- Pipe backfill shall be acceptable native material that can be compacted in place.
- Top 450mm of laneway backfill shall consist of 300mm Granular B and 150mm of Granular A placed in lifts and fully compacted.
- Minimum cover on laneway culverts shall be 300mm.
- Existing asphalt or concrete pavement or surface treatment shall be replaced by the Contractor.
- The width of surface restoration shall match the existing laneway.
- Contractor shall be responsible for correcting any backfill settlement during construction and during the warranty period.

The timing of laneway closures will be coordinated by the Contractor to the satisfaction of the landowner.

400.23 EXISTING CROSSING CLEANOUT

Where the Special Provisions require an existing crossing to be cleaned, the Contractor shall provide a bottom width and depth that provides capacity equivalent to the capacity of the channel on either side. Excavated materials shall be hauled away unless adjacent landowners give permission for leveling. Care shall be taken to ensure that existing abutments or any portion of the structure are not damaged or undercut. The method of removing the material is to be pre-approved by the Engineer.

400.24 FENCES

If the Contractor is responsible to remove and install fences, the following shall apply:

- All fences removed by a Contractor are to be re-erected in as good a condition as existing materials permit.
- All fences shall be properly stretched and fastened. Where directed by the Engineer, additional steel posts shall be placed to adequately support a fence upon re-erection.
- Where practical and where required by the landowner, the Contractor shall take down an existing fence at the nearest anchor post and roll the fence back rather than cutting the fence and attempting to patch it.
- Where fence materials are in such poor condition that re-erection is not possible, the Contractor shall replace the fence using equivalent materials. Such fence material shall be approved by the Engineer and the landowner. Where the Engineer approves new fence material, additional payment will be provided.

Any fences paralleling an open drain, that are not line fences, that hinder the proper working of the excavating machinery for drain construction or maintenance shall be removed and rebuilt by the

landowner at their own expense. If such parallel fences are line fences they shall be removed and reinstalled by the Contractor.

No excavated or cleared material shall be placed against fences.

The installation of all fences shall be done to the satisfaction of the Engineer and the landowner.

400.25 LIVESTOCK

If any construction will be within a fenced field containing livestock that are evident or have been made known to the Contractor, the Contractor shall notify the owner of the livestock 48 hours in advance of access into the field. Thereafter, the owner shall be responsible for the protection of the livestock in the field during construction and shall also be liable for any damage to or by the livestock.

Where the owner so directs or where the Contractor has failed to reach the owner, the Contractor shall adequately re-erect all fences at the end of each working day. No field containing livestock shall have a trench left open at the end of the working day, unless the trench has been adequately backfilled or protected. Failure of the Contractor to comply with this paragraph shall render the Contractor liable for any damage to or by the livestock.

Where livestock may be encountered on any property the Contractor shall notify the Engineer to arrange for inspection of the work prior to backfilling.

400.26 STANDING CROPS

The Contractor shall not be held responsible for damages to standing crops within the working area for the drain. However, the Contractor shall notify the owner of the crops 48 hours prior to commencement of construction so as to allow the owner an opportunity to harvest or salvage the crop within the drain working area. If this advance notice is not given the Contractor may be liable for the loss of the standing crops.

400.27 CLEARING VEGETATION

400.27.1 General

The area for clearing, if not defined elsewhere, shall be 15m on each side of the drain.

400.27.2 Trees to Remain

Where it is feasible to work around existing trees that do not impede the function of the drainage works, the Contractor shall not remove any deciduous tree larger than 300mm and any coniferous tree larger than 200mm, unless authorized by the Engineer.

400.27.3 Incidental Clearing

Incidental clearing includes removal of trees, brush or other vegetation with an excavator during construction activities, and the cost is to be included in the price for the related construction activity.

400.27.4 Power Brushing

Power brushing includes removal of above-ground vegetation with a rotary brush cutter or other mechanical means. Stump and root removal is not required. Power brushed vegetation in a channel cross-section shall be removed and leveled in the working area. Excavated material may be placed and leveled on power brushed vegetation.

400.27.5 Close-Cut Clearing

Close-cut clearing includes removal of above-ground vegetation cut flush with the ground. Stump and root removal is not required.

400.27.6 Clearing And Grubbing

Clearing and grubbing includes removal of vegetation, including stumps and roots. Removal of earth from the grubbed area into the windrows or piles is to be minimized.

400.27.7 Disposal of Cleared Vegetation

400.27.7.1 In Bush Areas

Cleared vegetation is to be pushed into windrows or piles at the edge of the cleared area. Stumps and roots are to be piled first at the edge of the cleared area, followed by other vegetation (trunks, branches, etc.). Provisions for lateral drainage are required through all windrows. Windrows are not to block any laneways or trails. After removing cleared vegetation, the working area shall be leveled to the satisfaction of the Engineer.

400.27.7.2 In Field Areas

Cleared vegetation resulting from incidental clearing or power brushing may be hauled away, mulched in place or reduced to a size that permits cultivation using conventional equipment without causing undue hardship on farm machinery.

Cleared vegetation resulting from close-cut clearing or clearing and grubbing is to be hauled away to an approved location. Disposal sites may be in bush areas or other approved locations on the same farm. No excavated material shall be levelled over any logs, brush or rubbish of any kind.

400.27.8 Landowner Requested Salvage

A landowner may request that wood be separated from the windrows for the landowner's future use. This additional work would be eligible for extra payment, subject to the approval of the Engineer. The cost of the additional work would be assessed to the landowner.

400.27.9 Clearing by Landowner

Wherever the Special Provisions indicate that clearing may be undertaken by the landowner, work by the landowner shall be in accordance with the Clearing Vegetation requirements of this specification and must be completed so as not to cause delay for the Contractor. If the landowner does not complete clearing in accordance with these requirements, the Contractor will undertake the clearing at a price approved by the Engineer.

400.28 ROCK REMOVAL

400.28.1 General

Rock shall be defined as bedrock and boulders that are greater than one-half cubic metre in size and that require blasting or hoe-ram removal. Bedrock or boulders that can be removed with a standard excavator bucket are not considered rock removal.

400.28.2 Blasting Requirements

All blasting shall be performed by a competent, qualified blaster in accordance with OPSS 120. Blasting mats are required. A pre-blast survey meeting the requirements of OPSS 120 must be completed for any structure within 200m of any blasting. The cost for pre-blast survey shall be included in the tender price for rock removal.

400.28.3 Typical Sections and Pay Limits

For tile drains and road culverts, rock shall be removed to 150mm below the proposed grade shown on the profile so that pipes are not in direct contact with rock. The width of rock removal shall be 1m minimum or the diameter of the pipe plus 600mm.

For open drains, rock removal shall match the proposed grade and bottom width shown on the Drawings. Side slopes shall be vertical or sloped outward. Side slopes shall be free of loose rock when excavation is completed.

Payment for the quantity of rock removed will be based on the typical sections described in these specifications and confirmed by field measurements. There will be no payment for overbreak.

400.28.4 Disposal of Rock

Excavated rock shall be piled at the edge of the working area at locations designated by the landowner. The cost to pile excavated rock shall be included in the tender price for rock removal. If the Special Provisions or the landowner require excavated rock to be hauled away, additional payment will be considered.

Where approved by the Engineer, excavated rock may be used in place of imported riprap.

400.29 SEEDING

400.29.1 General

Contractor responsible for re-seeding as necessary for uniform catch during warranty period. Areas that remain grassed after construction may not need to be seeded unless directed otherwise by the Engineer.

400.29.2 Drainage Works and Road Allowances

All disturbed ditch banks, berms and road allowances are to be seeded at the end of the day.

The following seed mixture shall be applied at 60kg/ha using a mechanical (cyclone) spreader:

- 35% Creeping Red Fescue
- 25% Birdsfoot Trefoil
- 25% Kentucky Bluegrass
- 10% Cover Crop (Oats, Rye, Barley, Wheat)
- 5% White Clover

Provide temporary cover for late fall planting by adding an additional 10 kg/ha of rye or winter wheat.

400.29.3 Hydroseeding

Where hydroseeding is specified, disturbed areas will be restored by the uniform application of a standard roadside mix, fertilizer, mulch and water at a rate of 2,000 kg/ha and be in accordance with OPSS 804.

400.29.4 Seeding Lawns

Unless specified otherwise, lawn areas shall be seeded with Canada No. 1 lawn grass mixture applied at 300 kg/ha using a mechanical (cyclone) spreader on 100mm of topsoil. Fertilizer shall be 5:20:20 or 10:10:10 applied at 300 kg/ha. Seed and fertilizer shall be applied together. Contractor shall arrange for watering with landowners.

400.29.5 Sod

Where sod is specified, sod is to be commercial grade turfgrass nursery sod, Kentucky Bluegrass placed on 50mm of topsoil. Fertilizer shall be 5-20-20 applied at 10kg/ha. Place sod in accordance with supplier instructions. Contractor is responsible for saturating the sod with water on the day of sod placement. Subsequent watering is the responsibility of the landowner.

400.30 EROSION CONTROL BLANKETS

Erosion Control Blankets (ECB) shall be biodegradable and made of straw/coconut (Terrafix SC200, Nilex SC32 or equal) or coconut (Terrafix C200, Nilex C32 or equal) with photodegradable, double net construction. The blanket and the staples shall be supplied and installed as per OPSS 804.

Erosion control blanket shall be placed and stapled into position as per the manufacturer's installation instructions on slopes as directed by the Engineer. Blankets shall be installed in direct contact with the ground surface to form a uniform, cohesive mat over the seeded earth area. The blankets are to be single course with 150mm overlap between blankets and joints are to be staggered. The Contractor shall ensure that the ECB is anchored to the soil and that tenting of the ECB does not occur.

On slopes, when the ECB cannot be extended 1m beyond the crest of the slope, the uppermost edge of the ECB shall be anchored in a 150mm wide by 150mm deep trench. The trench shall be backfilled with earth and compacted.

400.31 SEDIMENT CONTROL

400.31.1 General

Contractor shall install sediment control features at the downstream limits of the project and at other locations as shown on the drawings or directed by the Engineer.

Sediment control features shall be installed prior to any excavation taking place upstream of that location. The Contractor shall maintain all sediment control features throughout construction and the warranty period.

Sediment that accumulates during construction shall be removed and levelled as required.

400.31.2 Flow Check Dams

400.31.2.1 Temporary Straw Bale Flow Check Dam

The straw bale flow check dam shall consist of a minimum of 3 bales. Each bale is to be embedded at least 150mm into the channel bottom and shall be anchored in place with 2 T-bar fence posts or 1.2m wooden stakes driven through the bale.

Straw bales shall be hauled away at the end of the warranty period. Accumulated sediments shall be excavated and levelled when the temporary straw bale flow check dam is removed.

400.31.2.2 Temporary Rock Flow Check Dam

The temporary rock flow check dam shall extend to the top of the banks so that dam overtopping does not cause bank erosion. Rock shall be embedded a minimum of 150mm into the ditch bottom and banks. No geotextile is required for temporary rock flow check dams.

Accumulated sediments shall be excavated and levelled when the temporary rock flow check dam is removed at the conclusion of the warranty period.

400.31.2.3 Permanent Rock Flow Check Dam

The requirements of temporary rock flow check dams shall apply except rock shall be placed on geotextile and the dam shall remain in place permanently.

400.31.3 Sediment Traps

400.31.3.1 *General*

The channel bottom shall be deepened in accordance with the dimensions provided in the Drawings or Special Provisions. If dimensions are not specified on the Drawings, the sediment trap shall be excavated within the channel cross-section at least 0.3m below the design grade.

The Contractor will monitor the sediment trap during construction and cleanout accumulated sediments as required to maintain the function of the sediment trap.

If specified to be temporary, no sediment trap maintenance is required after construction is complete.

If specified to be permanent, the contractor will clean out the sediment trap at the conclusion of the warranty period, unless directed otherwise by the Engineer.

400.31.3.2 *Sediment Trap with Flow Check Dam*

A permanent rock sediment trap shall include a permanent sediment trap and a rock flow check dam.

A temporary rock/straw sediment trap shall include a temporary sediment trap and a rock/straw flow check dam.

400.31.4 Turbidity Curtains

A turbidity curtain is required when there is permanent water level/flow and a sediment trap is not feasible.

Turbidity curtains shall be in accordance with OPSS 805 and installed per manufacturer's instructions.

Turbidity curtains shall be sized and anchored to ensure the bottom edge of the curtain is continuously in contact with the waterbody bed so that sediment passage from the enclosed area is prevented. The curtain must be free of tears and capable of passing the base flow from the drainage works. Turbidity curtain locations may be approved by the Engineer.

Turbidity curtains are to remain functional until work in the enclosed area is completed. Prior to relocating or removing turbidity curtains, accumulated sediment is to be removed from the drain and levelled.

Where a turbidity curtain remains in place for more than two weeks it shall be inspected for damage or clogging and replaced, repaired or cleaned as required.

400.31.5 Silt Fence

Silt fence shall be in accordance with OPSS 805.07.02.02 and OPSD 219.110 (light-duty).

400.32 GRASSED WATERWAYS AND OVERFLOW SWALES

Grassed waterways and overflow swales typically follow low ground along the historic flow route. The cross-section shall be saucer shaped with a nominal 1m bottom width, 8:1 side slopes and 300mm depth unless stated otherwise in the Special Provisions.

All grassed waterways are to be permanently vegetated. Grassed waterways shall be seeded with the following permanent seed mixture: 50% red fescue, 45% perennial ryegrass and 5% white clover, broadcast at 80 kg/ha. Fertilizer to be 7-7-7 applied at 80 kg/ha.

Provide temporary cover for late fall planting by adding an additional 10 kg/ha of rye or winter wheat.

Overflow swales may be cropped using conventional farming practice.

400.33 BUFFER STRIPS

Open drains shall include minimum 3m wide, permanently vegetated buffer strips on each side of the drain. Catchbasins shall include a minimum 1m radius, vegetated buffer strip around the catchbasin.

Cultivation of buffer strips using conventional farming practice may be undertaken, provided sediment transport into the drain is minimized.

400.34 MAINTENANCE CORRIDOR

The maintenance corridor along the route of the drain, as established in the report, shall be kept free of obstructions, ornamental vegetation and structures. When future maintenance is undertaken, the cost of removing such items from the corridor shall be assessed to the landowner.

400.35 POLLUTION

The Contractor shall keep their equipment in good repair. The Contractor or any landowner shall not spill or cause to flow any polluted material into the drain that is not acceptable to the MOECC. The local MOECC office and the Engineer shall be contacted if a polluted material enters the drain. The Contractor shall refill or repair equipment away from open water. If the Contractor causes a spill, the Contractor is responsible to clean-up the spill in accordance with MOECC clean-up protocols.

400.36 SPECIES AT RISK

If a Contractor encounters a known Species At Risk designated by the MNR or DFO, the Contractor shall notify the Engineer immediately and follow the Ministry's guidelines for work around the species.

STANDARD SPECIFICATIONS

FOR

OPEN DRAINS

TABLE OF CONTENTS

410.1 DESCRIPTION..... 1

410.2 MATERIALS 1

410.3 CONSTRUCTION..... 1

 410.3.1 Excavation..... 1

 410.3.2 Low Flow Channels 1

 410.3.3 Line 1

 410.3.4 Grade Control..... 1

 410.3.5 Variation from Design Grade 2

 410.3.6 Excavated Material 2

 410.3.7 Excavation at Existing Bridge and Culvert Sites 3

 410.3.8 Bridges and Culverts 3

 410.3.9 Obstructions 3

 410.3.10 Tile Outlets 4

 410.3.11 Completion 4

410.1 DESCRIPTION

Work under this item shall include the supply of labour, equipment and materials required for: channel excavation to the cross-section specified, leveling or disposal of all excavated material (spoil) as directed, reconstruction of all intercepted drains as required and any other items related to open drain construction as required by the Schedule of Tender Prices, Special Provisions or the Drawings.

410.2 MATERIALS

Refer to Section 400, Standard Specifications for Drain Construction for any materials required for open drain construction.

410.3 CONSTRUCTION**410.3.1 Excavation**

The bottom width and the side slopes of the ditch shall be as shown on the profile drawing. If the channel cross-section is not specified in the Special Provisions it shall be a 1m bottom width with 1.5m horizontal to 1m vertical (1.5:1) bank slope. At locations along the drain where the specified side slopes change there shall be a transitional length of not less than 5m between the varying side slopes. At locations along the drain where the specified bottom width changes there shall be a transitional length of not less than 5m. In all cases there shall be a smooth transition between changes in any part of the channel cross-section. Where the bottom width of the existing ditch matches the specified bottom width, ditch excavation shall be completed without disturbing existing banks.

410.3.2 Low Flow Channels

Unless specified otherwise in the Special Provisions, all intermittent open drains with a bottom width greater than 1.8m and a grade less than 0.07%, shall have a low flow channel. The bottom of the low flow channel shall be the grade shown on the profiles.

The low flow channel shall have a U-shaped cross-section with an average top width of 0.5m and a minimum depth of 0.3m. The low flow channel will not be seeded and may meander along the main channel bottom provided it remains at least .3m from the toe of main channel bank slope.

410.3.3 Line

The drain shall be constructed according to the alignment shown on the drawings or shall follow the course of the existing ditch. All bends shall have a minimum inside radius of 2m. There shall be a smooth transition between changes in the channel alignment. The Contractor shall contact the Engineer before removing any bends or irregularities in an existing ditch.

410.3.4 Grade Control

The profile shows the grade line for the bottom of the ditch. Cuts may be shown on the profile from the existing top of bank and/or from the existing ditch bottom to the new ditch bottom. These cuts are shown for the convenience of the Contractor and are not recommended for quantity estimate or grade control. Accurate grade control must be maintained by the Contractor during ditch excavation. The ditch bottom elevation should be checked every 50 metres and compared to the elevation on the profile.

Benchmarks are identified on the Contract Drawings. The Engineer will confirm all benchmark elevations prior to construction.

410.3.5 Variation from Design Grade

A variation of greater than 25mm above the design grade line may require re-excavation. Excavation below design grade up to 150mm is recommended so that sediment accumulation during or following excavation will not place the ditch bottom above the design grade at completion. Under some circumstances the Engineer may direct that over excavation greater than 200mm will have to be backfilled. No additional payment will be made if backfilling is required to remedy over excavation.

410.3.6 Excavated Material

Excavated material (spoil) shall be deposited on either or both sides of the drain within the specified working area as directed in the Special Provisions. The Contractor shall verify the location for the spoil with each landowner before commencing work on their property. If not specified, spoil shall be placed on the low side of the ditch or opposite trees and fences. The spoil shall be placed a minimum 1m from the top of the bank. No excavated material shall be placed in tributary drains, depressions, or low areas such that water is trapped behind the spoil bank. Swales shall be provided through the leveled or piled spoil at approximately 60m intervals to prevent trapping water behind the spoil bank.

The excavated material shall be placed and leveled to a maximum depth of 250mm; unless otherwise instructed. If excavating more than 450mm topsoil shall be stripped, stockpiled separately and replaced over the leveled spoil, unless stated otherwise in the Special Provisions. The edge of the spoil bank furthest from the ditch shall be feathered down to existing ground. The edge of the spoil bank nearest the ditch shall have a maximum slope of 2:1. The material shall be leveled such that it may be cultivated with conventional equipment without causing undue hardship on farm machinery.

Wherever clearing is necessary prior to leveling, the Contractor shall remove all stumps and roots from the working area. No excavated material shall cover any logs, brush or rubbish of any kind. Large stones in the leveled spoil that are greater than 300mm in diameter shall be moved to the edge of the spoil bank nearest to the ditch but in general no closer than 1m to the top of bank.

Lateral channels that outlet into the drain shall be tapered over a distance of 10m to match the grade of drain excavation. No additional payment will be made for this work.

Where the elevation difference between the lateral channel and the drain is greater than 450mm, a rock chute or similar bank protection approved by the Engineer shall be provided. Additional payment may be allowed for this work.

Where it is specified to straighten any bends or irregularities in the alignment of the ditch or to relocate any portion of an existing ditch, the excavation from the new cut shall be used for backfilling the original ditch. Regardless of the distance between the new ditch and old ditch, no additional payment will be allowed for backfilling the existing ditch.

The Contractor shall contact the Engineer if a landowner indicates in writing that spoil on the owner's property does not need to be leveled. The Engineer may release the Contractor from the obligation to level the spoil and the Engineer shall determine the credit to be applied to the Contractor's payment. No additional compensation is provided to the owner if the spoil is not leveled.

The Engineer may require the Contractor to obtain written statements from any or all of the landowners affected by the leveling of the spoil. Final determination on whether or not the leveling of spoil meets the specification shall be made by the Engineer.

410.3.7 Excavation at Existing Bridge and Culvert Sites

The Contractor shall excavate the drain to the specified depth under all bridges and to the full width of the structure unless specified otherwise in the Special Provisions. All necessary care and precautions shall be taken to protect permanent structures. Temporary bridges may be removed and left on the bank of the drain. In cases where the design grade line falls below the top of footings, the Contractor shall take care to not over-excavate below the grade line. The Contractor shall notify the Engineer if excavation of the channel exposes the footings of the bridge or culvert, so the Engineer can make an evaluation.

The Contractor shall clean through all pipe culverts to the grade line and width specified on the profile. The Contractor shall immediately contact the Engineer after a culvert cleanout if it is found that the culvert bottom is above the grade line or where the structural integrity of the culvert is questionable.

Material resulting from cleanout through bridges or culverts shall be levelled on the adjacent private lands or hauled offsite at the expense of the bridge/culvert owner.

410.3.8 Bridges and Culverts

The size and material for any new ditch crossings shall be as outlined in the Special Provisions.

For culvert installation instructions, refer to the General Specifications for Drain Construction and the Drawings.

Any crossings assembled on-site shall be assembled in accordance with the manufacturer's specifications.

If directed on the drawings that the existing crossing is to be salvaged for the owner, the Contractor shall carefully remove the existing crossing and place it beside the ditch or haul to a location as specified by the owner. If the existing crossing is not to be saved then the Contractor shall remove and dispose of the existing crossing. Disposal by burying on-site must be approved by the Engineer and the owner.

All new pipe crossings shall be installed at the invert elevations as specified on the Drawings, usually a minimum of 50mm below design grade. If the ditch is over excavated greater than 200mm below design grade the Contractor shall confirm with the Engineer the elevations for installation of the new pipe crossing.

For backfill and surface restoration, refer to the General Specifications for Drain Construction and the Drawings.

Installation of private crossings during construction must be approved by the Engineer.

410.3.9 Obstructions

All trees, brush, fallen timber and debris shall be removed from the ditch cross-section and as required for spreading of the spoil. The roots shall be left in the banks if no bank excavation is required as part of the new channel excavation. In wooded or heavily overgrown areas all cleared material may be pushed into piles or rows along the edge of the cleared path and away from leveled spoil. All dead trees along either side of the drain that may impede the performance of the drain if allowed to remain and fall into the ditch, shall be removed and put in piles, unless directed otherwise by the Engineer.

410.3.10 Tile Outlets

The location of all existing tile outlets may not be shown on the profile for the drain. The Contractor shall contact each owner and ensure that all tile outlets are marked prior to commencing excavation on the owner's property. If a marked tile outlet or the tile upstream is damaged due to construction, it shall be replaced at the Contractor's expense. Additional payment will be allowed for the repair or replacement of any unmarked tile outlets encountered during excavation. In all cases, if an existing tile outlet requires replacement the Contractor shall confirm the replacement tile outlet with the Engineer. Where riprap protection exists at any existing tile outlet such protection shall be removed and replaced as necessary to protect the outlet after reconstruction of the channel.

If any tile outlet becomes plugged as a result of construction, the Contractor shall remove the obstruction.

410.3.11 Completion

At the time of final inspection, all work in the contract shall have the full dimensions and cross-sections specified.

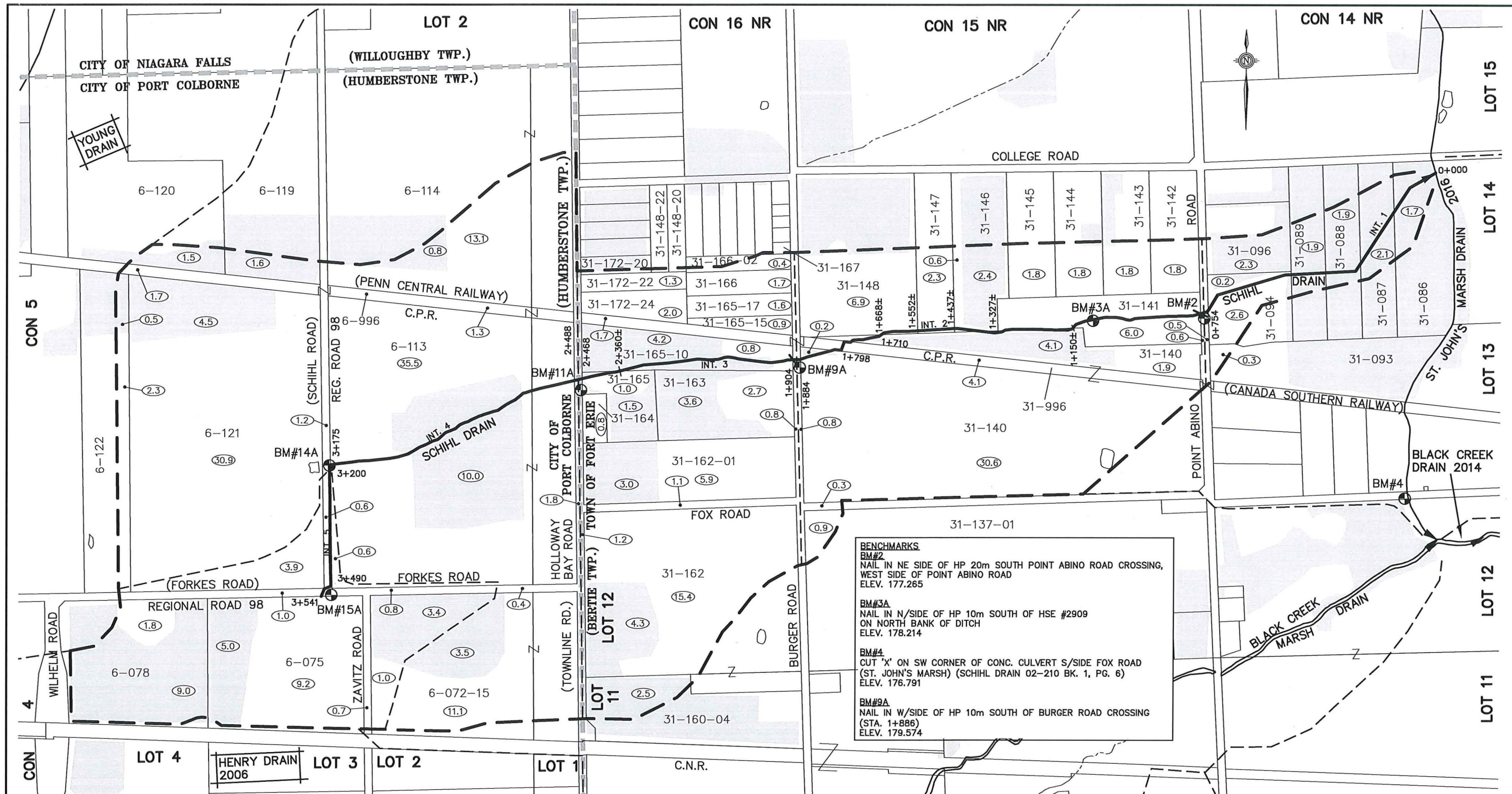

NOTES:
 -ALL ROLL NO'S IN TOWN OF FORT ERIE BEGIN WITH 27-03-020-0 EG. 31-161 IN FULL IS 27-03-020-031-161
 -ALL ROLL NO'S IN CITY OF PORT COLBORNE BEGIN WITH 040-00 EG. 6-077 IS 27-11-040-006-077

THE POSITION OF POLE LINES, CONDUITS, WATERMANS, SEWERS AND OTHER UNDERGROUND AND OVERGROUND UTILITIES AND STRUCTURES IS NOT NECESSARILY SHOWN ON THE CONTRACT DRAWINGS, AND, WHERE SHOWN, THE ACCURACY IS NOT GUARANTEED. BEFORE STARTING WORK, THE CONTRACTOR SHALL INFORM THEMSELVES OF THE EXACT LOCATION OF ALL SUCH UTILITIES AND STRUCTURES, AND SHALL ASSUME ALL LIABILITY FOR DAMAGE TO THEM.

PLAN LEGEND

- MAJOR WATERSHED
- ... INTERMEDIATE WATERSHED
- PROPOSED WORK
- Z DENOTES PROPERTY OWNERSHIP ON BOTH SIDES OF LOT LINE
- LIMIT BETWEEN MUNICIPALITIES
- (12.8) APPROXIMATE HECTARES IN WATERSHED
- (31-160-04) ASSESSMENT ROLL NUMBER
- BUSH

DESIGNED BY: N.W.M.
 CHECKED BY: N.W.M.
 DRAWN BY: N.M.B.
 CHECKED BY: N.W.M.

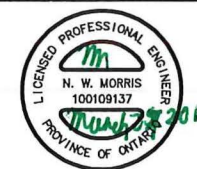

SCALE
 0 100 200m
 1:10,000
 (ON 11"x17")

NOTE: BASE MAPPING PROVIDED BY THE TOWN OF FORT ERIE

SCHIHLE DRAIN
 TOWN OF FORT ERIE
 REGION OF NIAGARA CITY OF PORT COLBORNE

WATERSHED PLAN	MAR. 28, 2019
K. SMART ASSOCIATES LIMITED CONSULTING ENGINEERS AND PLANNERS KITCHENER SUDBURY	REVISED: JOB NUMBER: 02-210 DRAWING 1 OF 12

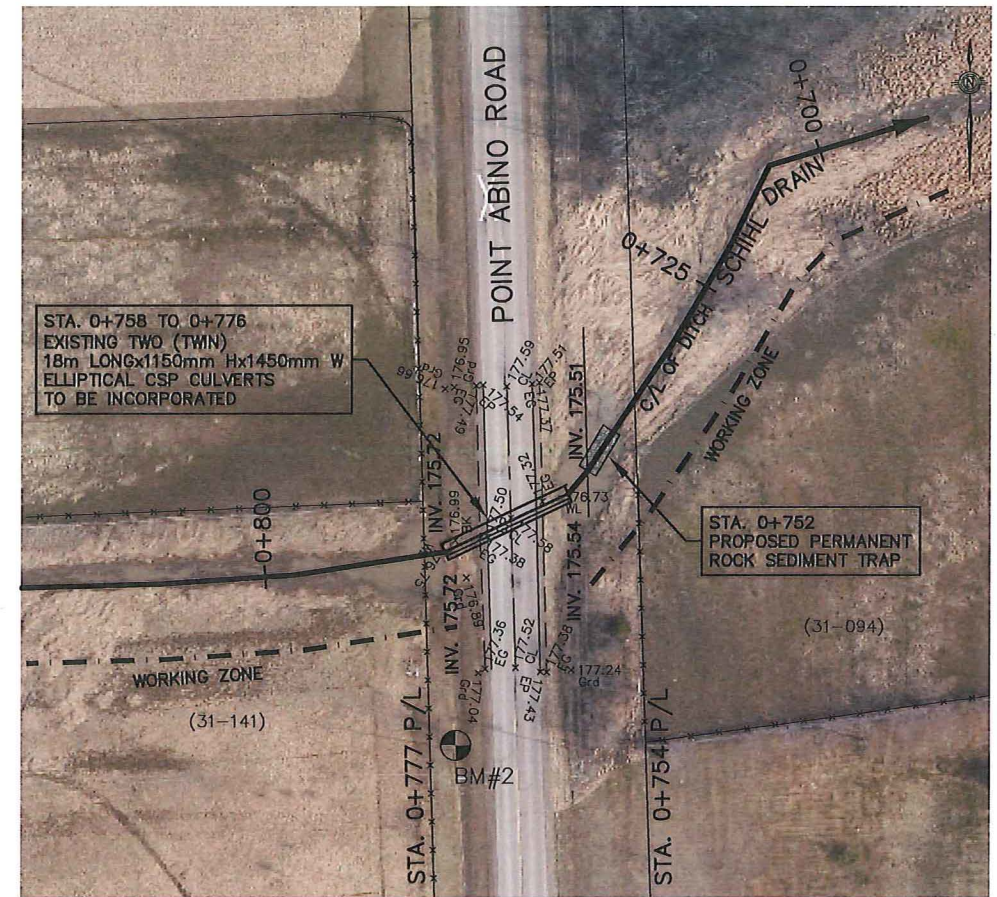
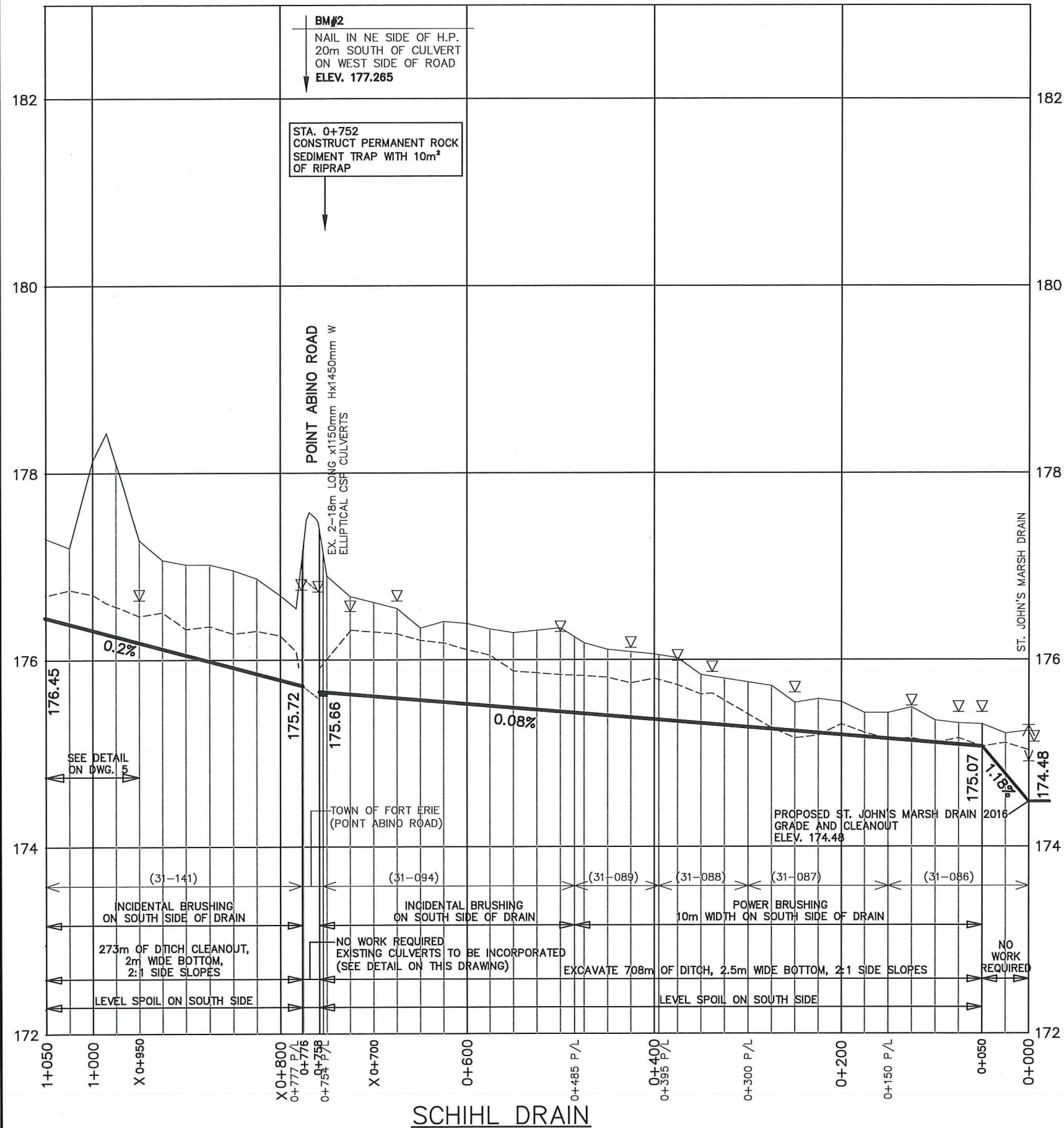

DETAIL STA. 0+754 TO 0+777
 SCALE 1:1000 (ON 11"x17")

LEGEND

- ▽ WATER LEVEL AT TIME OF SURVEY
- TILE OUTLET
- EXISTING CULVERT
- F/L FENCE LINE
- P/L PROPERTY LINE
- × CROSS SECTION LOCATION
- GROUND LEVEL (BANK)
- - - EXISTING DITCH BOTTOM
- GRADE FOR PROPOSED DRAIN
- INVERT FOR PROPOSED DRAIN
- - - EXISTING EDGE OF GRAVEL
- × × EXISTING FENCE
- - - PROPOSED RIGHT OF WAY

DESIGNED BY: N.W.M.		SCALE 0 50 100m (SCALE 1:5000) HORZ. 0 1m (SCALE 1:50) VERT. (ON 11"x17")
CHECKED BY: N.W.M.		
DRAWN BY: C.J.M.		
CHECKED BY: N.W.M.		
FIELD BOOK: 02-210	SCHIHL DRAIN	
REGION OF NIAGARA		TOWN OF FORT ERIE CITY OF PORT COLBORNE
MAIN DRAIN PROFILE		MAR. 28, 2019
K. SMART ASSOCIATES LIMITED CONSULTING ENGINEERS AND PLANNERS KITCHENER SUDBURY		REVISED:
		JOB NUMBER: 02-210
		DRAWING 2 OF 12

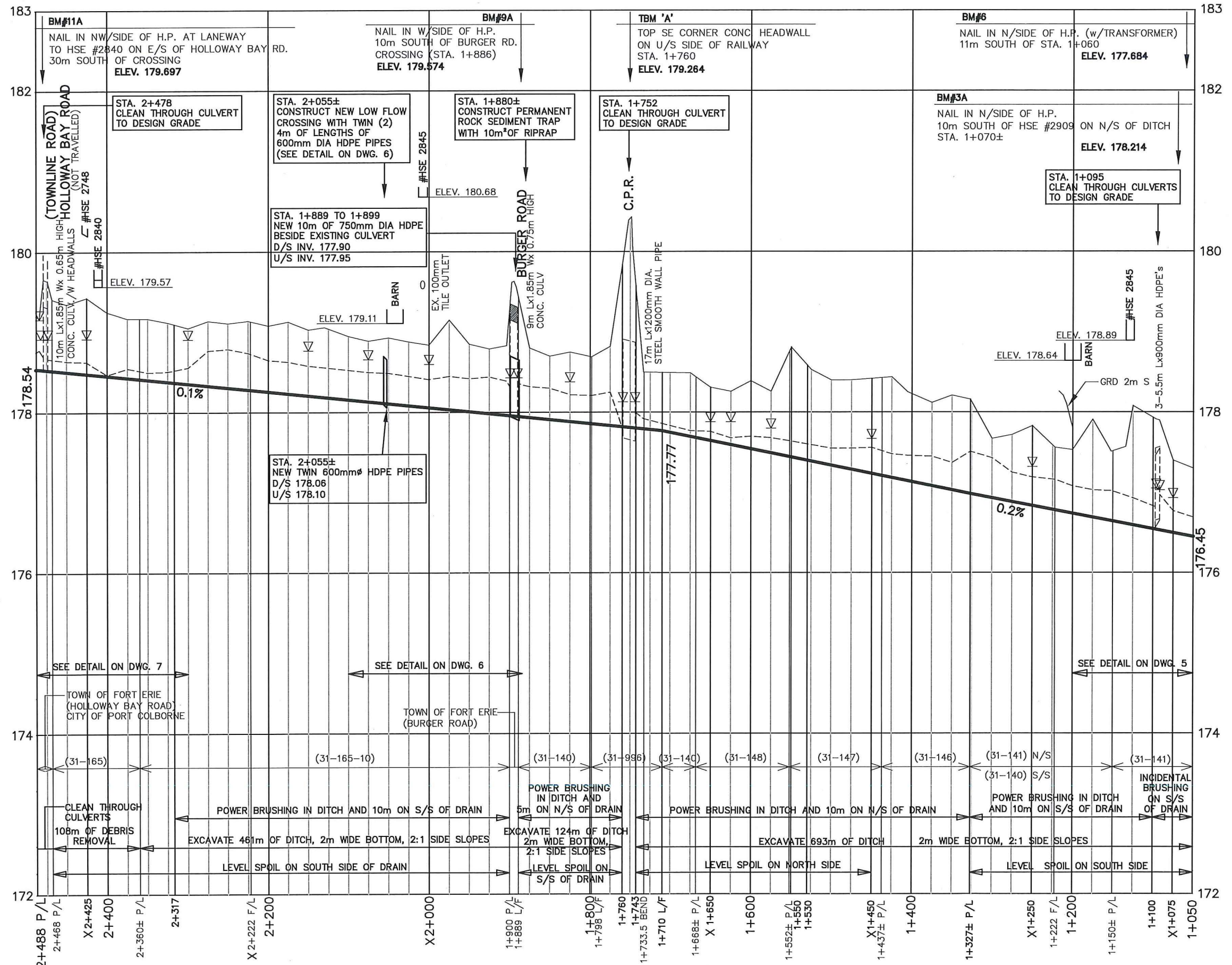

LEGEND

- ▽ WATER LEVEL AT TIME OF SURVEY
- TILE OUTLET
- EXISTING CULVERT
- F/L FENCE LINE
- P/L PROPERTY LINE
- × CROSS SECTION LOCATION

— GROUND LEVEL (BANK)
 - - - EXISTING DITCH BOTTOM
 — GRADE FOR PROPOSED DRAIN
 - - - INVERT FOR PROPOSED DRAIN

DESIGNED BY: N.W.M.		SCALE
CHECKED BY: N.W.M.		0 50 100m
DRAWN BY: N.M.B.		(SCALE 1:5000)
CHECKED BY: N.W.M.		0 1m
FIELD BOOK: 02-210		(SCALE 1:50)
		(ON 11"x17")

SCHIHLE DRAIN

REGION OF NIAGARA TOWN OF FORT ERIE
CITY OF PORT COLBORNE

MAIN DRAIN PROFILE CONTINUED MAR. 28, 2019

	K. SMART ASSOCIATES LIMITED CONSULTING ENGINEERS AND PLANNERS KITCHENER SUDBURY	REVISED:
		JOB NUMBER: 02-210
		DRAWING: 3 OF 12

SCHIHLE DRAIN CONT'D

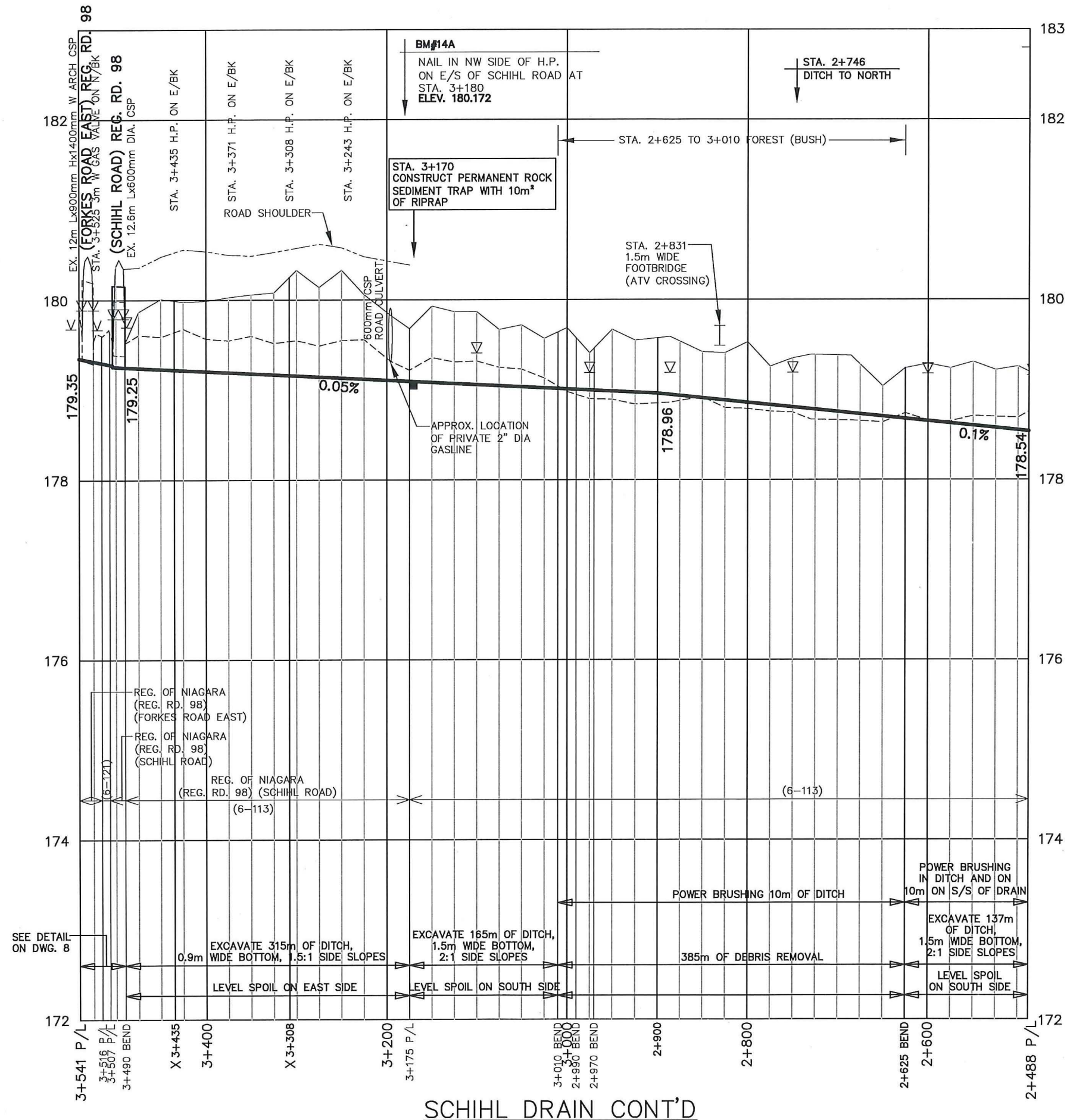

SCHIHL DRAIN CONT'D

LEGEND

- ▽ WATER LEVEL AT TIME OF SURVEY
- TILE OUTLET
- ▭ EXISTING CULVERT
- F/L FENCE LINE
- P/L PROPERTY LINE
- × CROSS SECTION LOCATION

GROUND LEVEL (BANK)
 EXISTING DITCH BOTTOM
 GRADE FOR PROPOSED DRAIN
 INVERT FOR PROPOSED DRAIN

0.2%
 175.07

DESIGNED BY: N.W.M.		SCALE 0 50 100m (SCALE 1 : 5000) HORZ.
CHECKED BY: N.W.M.		0 1m (SCALE 1 : 50) VERT. (ON 11"x17")
DRAWN BY: N.M.B.		
CHECKED BY: N.W.M.		
FIELD BOOK: 02-210		

SCHIHL DRAIN
 REGION OF NIAGARA TOWN OF FORT ERIE
 CITY OF PORT COLBORNE

MAIN DRAIN PROFILE CONTINUED MAR. 28, 2019

	K. SMART ASSOCIATES LIMITED CONSULTING ENGINEERS AND PLANNERS KITCHENER SUDBURY	REVISED:
		JOB NUMBER: 02-210
		DRAWING
		4 OF 12

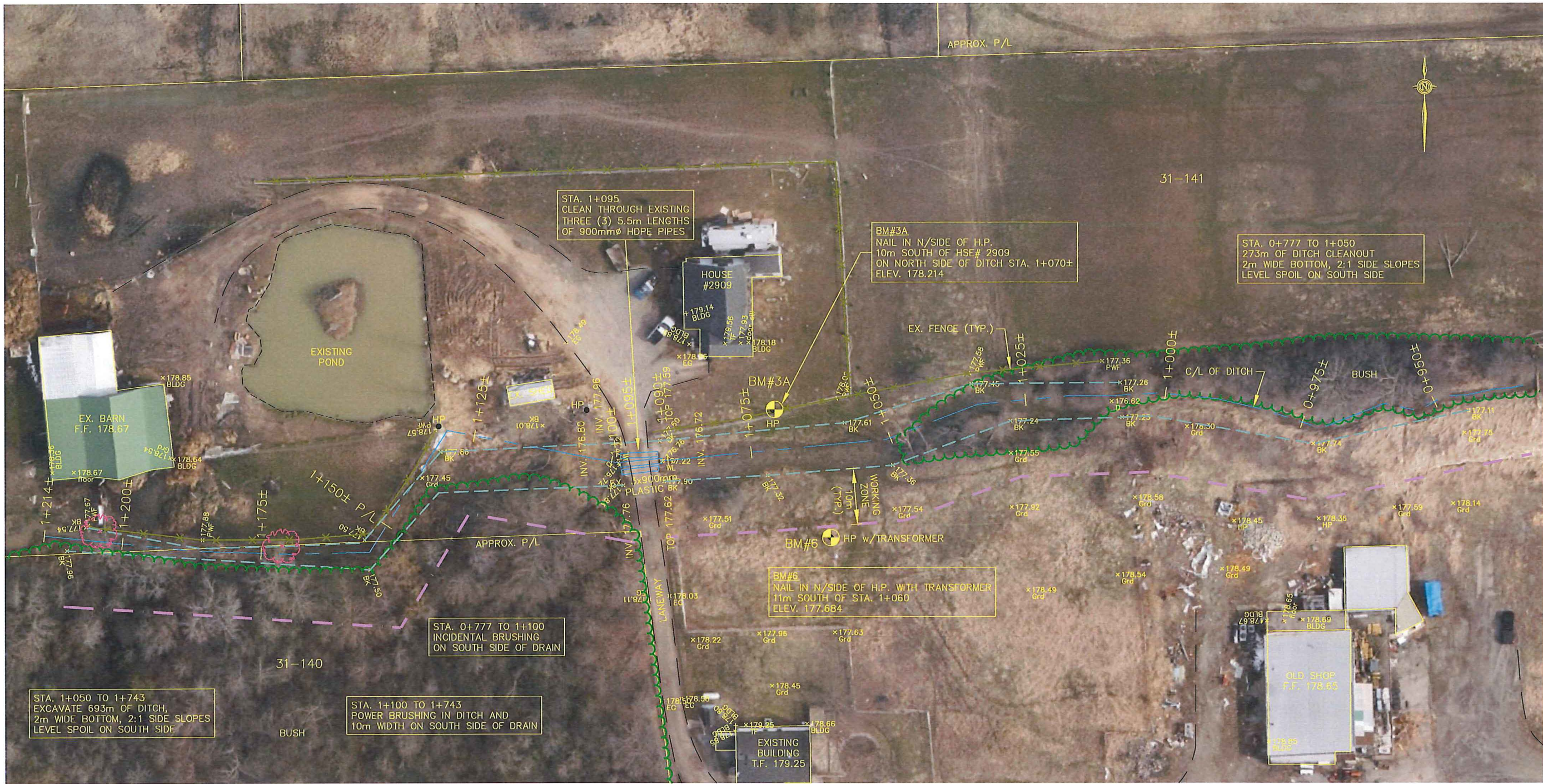

STA. 1+050 TO 1+743
EXCAVATE 693m OF DITCH,
2m WIDE BOTTOM, 2:1 SIDE SLOPES
LEVEL SPOIL ON SOUTH SIDE

STA. 1+100 TO 1+743
POWER BRUSHING IN DITCH AND
10m WIDTH ON SOUTH SIDE OF DRAIN

STA. 0+777 TO 1+100
INCIDENTAL BRUSHING
ON SOUTH SIDE OF DRAIN

STA. 1+095
CLEAN THROUGH EXISTING
THREE (3) 5.5m LENGTHS
OF 900mm ϕ HDPE PIPES

BM#3A
NAIL IN N/SIDE OF H.P.
10m SOUTH OF HSE# 2909
ON NORTH SIDE OF DITCH STA. 1+070 \pm
ELEV. 178.214

STA. 0+777 TO 1+050
273m OF DITCH CLEANOUT
2m WIDE BOTTOM, 2:1 SIDE SLOPES
LEVEL SPOIL ON SOUTH SIDE

BM#6
NAIL IN N/SIDE OF H.P. WITH TRANSFORMER
11m SOUTH OF STA. 1+060
ELEV. 177.684

LEGEND	
	EXISTING DITCH
	EXISTING EDGE OF GRAVEL
	EXISTING FENCE
	BUSH LIMIT
	PROPOSED RIGHT OF WAY

SCHIHLE DRAIN
REGION OF NIAGARA TOWN OF FORT ERIE
CITY OF PORT COLBORNE

DESIGNED BY: N.W.M.
CHECKED BY: N.W.M.
DRAWN BY: N.M.B.
CHECKED BY: N.W.M.
FIELD BOOK: 02-210

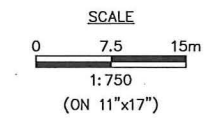

DETAIL STA. 0+050 TO 1+214 MAR. 28, 2019

K. SMART ASSOCIATES LIMITED CONSULTING ENGINEERS AND PLANNERS KITCHENER SUDBURY	REVISED:
	JOB NUMBER: 02-210
	DRAWING: 5 OF 69



STA. 2+055±
 CONSTRUCT NEW LOW FLOW CROSSING WITH
 TWIN (2) 4m LENGTHS OF 600mm DIA HDPE
 PIPES WITH 10m² RIPRAP AT EACH END
 AND 3m WIDE LANEWAY (40m² RIPRAP TOTAL)
 D/S INV.'s 178.06
 U/S INV.'s 178.10

LEGEND	
	EXISTING DITCH
	EXISTING EDGE OF GRAVEL
	EXISTING FENCE
	BUSH LIMIT
	PROPOSED RIGHT OF WAY

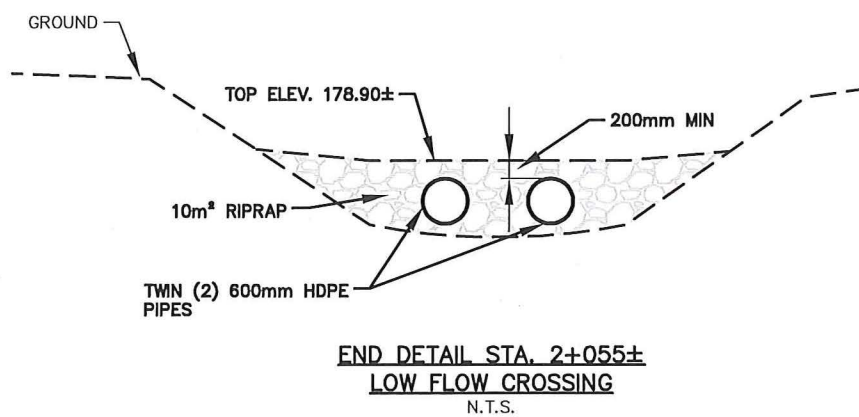

BM#9A
 NAIL IN W/SIDE OF H.P.
 10m SOUTH OF BURGER ROAD CROSSING
 (STA. 1+886±)
 ELEV. 179.574

DESIGNED BY: N.W.M.
 CHECKED BY: N.W.M.
 DRAWN BY: N.M.B.
 CHECKED BY: N.W.M.
 FIELD BOOK: 02-210

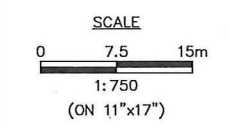
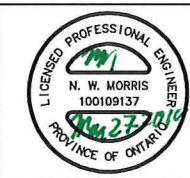

SCHIHLE DRAIN	
REGION OF NIAGARA TOWN OF FORT ERIE CITY OF PORT COLBORNE	
DETAIL STA. 1+884 TO 2+100	MAR. 28, 2019
K. SMART ASSOCIATES LIMITED CONSULTING ENGINEERS AND PLANNERS KITCHENER SUDBURY	
REVISED: _____ JOB NUMBER: 02-210 DRAWING: 6 OF 12	



STA. 2+478
CLEAN THROUGH EXISTING
10m LONG x 1.85m WIDE
CONCRETE CULVERT

STA. 2+410 TO 2+418
CAUTION:
DO NOT DISTURB POOL.
WORK AROUND IT.

STA. 1+899 TO 2+360
EXCAVATE 461m OF DITCH
2m WIDE BOTTOM, 2:1 SIDE SLOPES
LEVEL SPOIL ON SOUTH SIDE

STA. 1+899 TO 2+317±
POWER BRUSHING IN DITCH
AND 10m ON SOUTH SIDE

STA. 2+360 TO 2+473
113m OF DEBRIS REMOVAL
PLACE SPOIL ON SOUTH SIDE OF DTICH

BM#11A
NAIL IN W/SIDE OF H.P.
AT LANEWAY TO HSE #2840
ON E/S OF HOLLOWAY BAY ROAD
30m SOUTH OF CROSSING
ELEV. 179.697

LEGEND	
	EXISTING DITCH
	EXISTING EDGE OF GRAVEL
	EXISTING FENCE
	BUSH LIMIT
	PROPOSED RIGHT OF WAY

DESIGNED BY: N.W.M.
CHECKED BY: N.W.M.
DRAWN BY: N.M.B.
CHECKED BY: N.W.M.
FIELD BOOK: 02-210

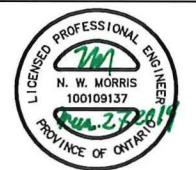

SCALE
0 7.5 15m
1:750
(ON 11"x17")

SCHIHLE DRAIN
REGION OF NIAGARA TOWN OF FORT ERIE
CITY OF PORT COLBORNE

DETAIL STA. 2+300 TO 2+488 MAR. 28, 2019

K. SMART ASSOCIATES LIMITED
CONSULTING ENGINEERS AND PLANNERS
KITCHENER SUDBURY

REVISED:
JOB NUMBER: 02-210
DRAWING: 7 OF 72

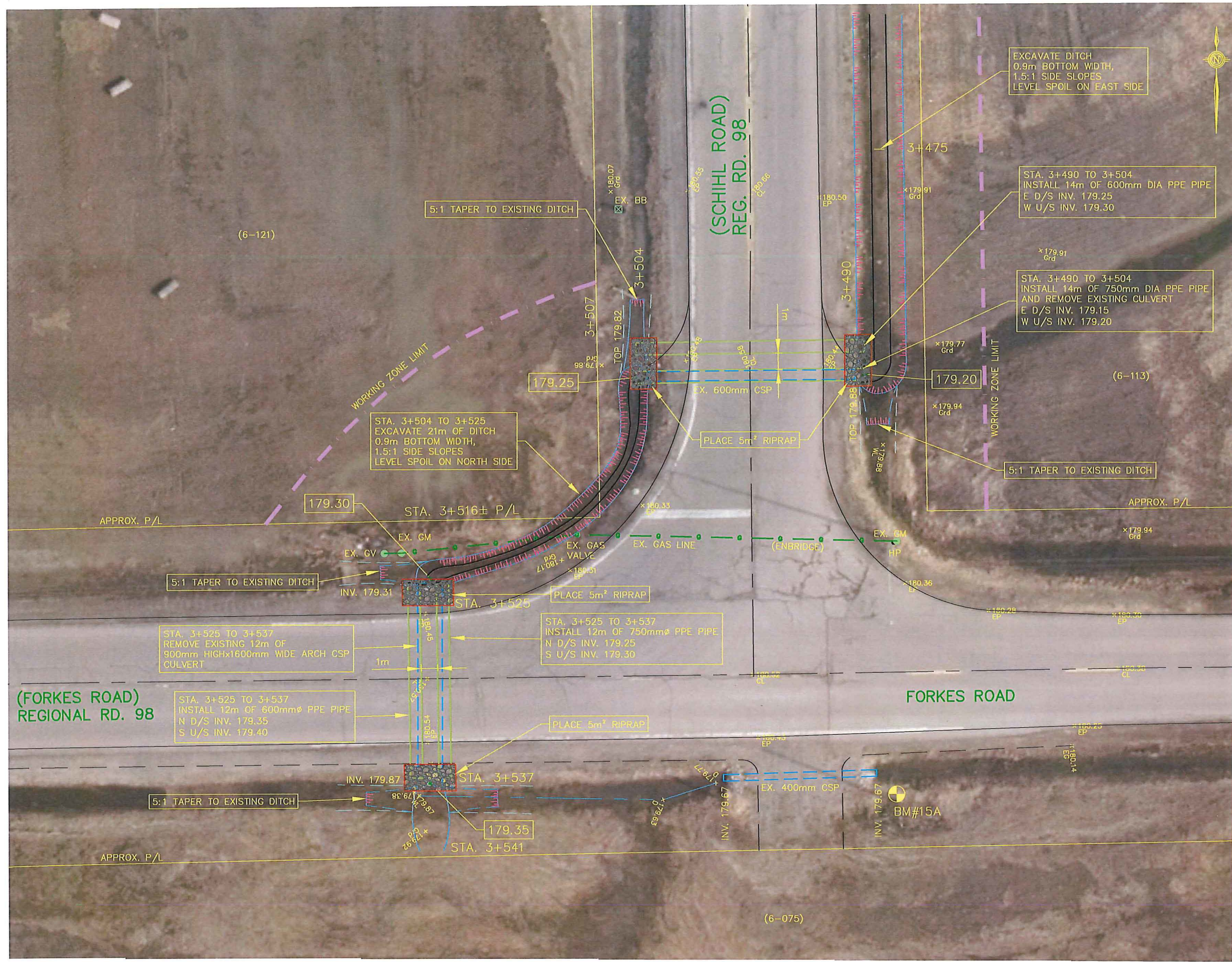

BM#15A
 NAIL IN NORTH SIDE OF H.P.
 ON SOUTH SIDE OF FORKES ROAD EAST
 ELEV. 180.277

LEGEND

	EXISTING GAS LINE
	EXISTING BANK
	PROPOSED RIGHT OF WAY

DESIGNED BY: N.W.M.
 CHECKED BY: N.W.M.
 DRAWN BY: N.M.B.
 CHECKED BY: N.W.M.
 FIELD BOOK: 02-210

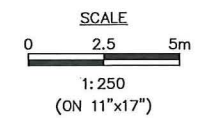

SCHIHLE DRAIN	
REGION OF NIAGARA	TOWN OF FORT ERIE CITY OF PORT COLBORNE
DETAIL STA. 3+490 TO 3+541	MAR. 28, 2019
K. SMART ASSOCIATES LIMITED CONSULTING ENGINEERS AND PLANNERS KITCHENER SUDBURY	REVISED:
	JOB NUMBER: 02-210
	DRAWING: 8 OF 72

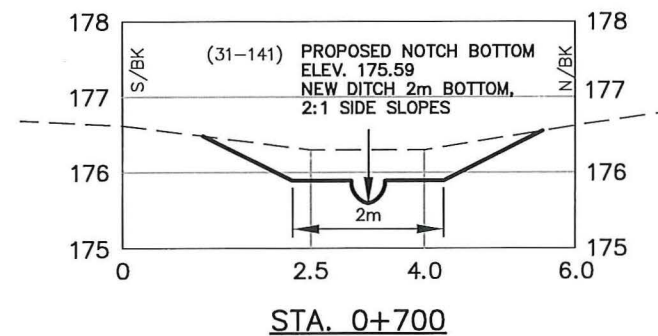
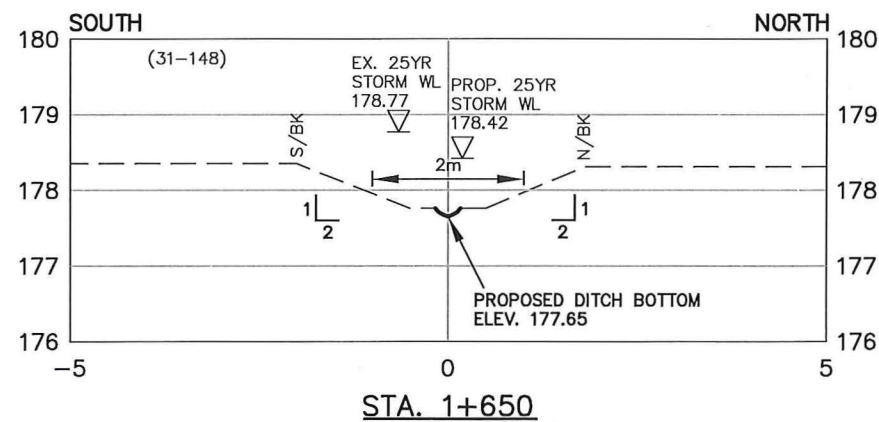
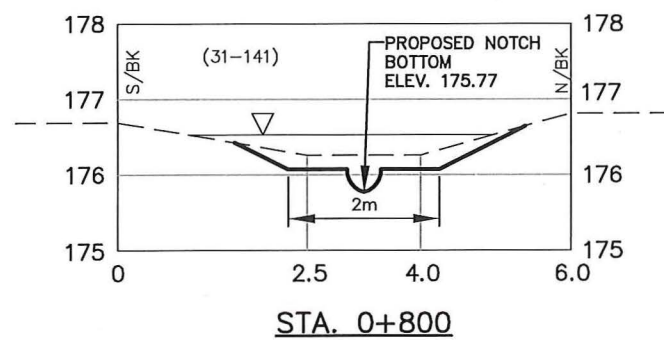
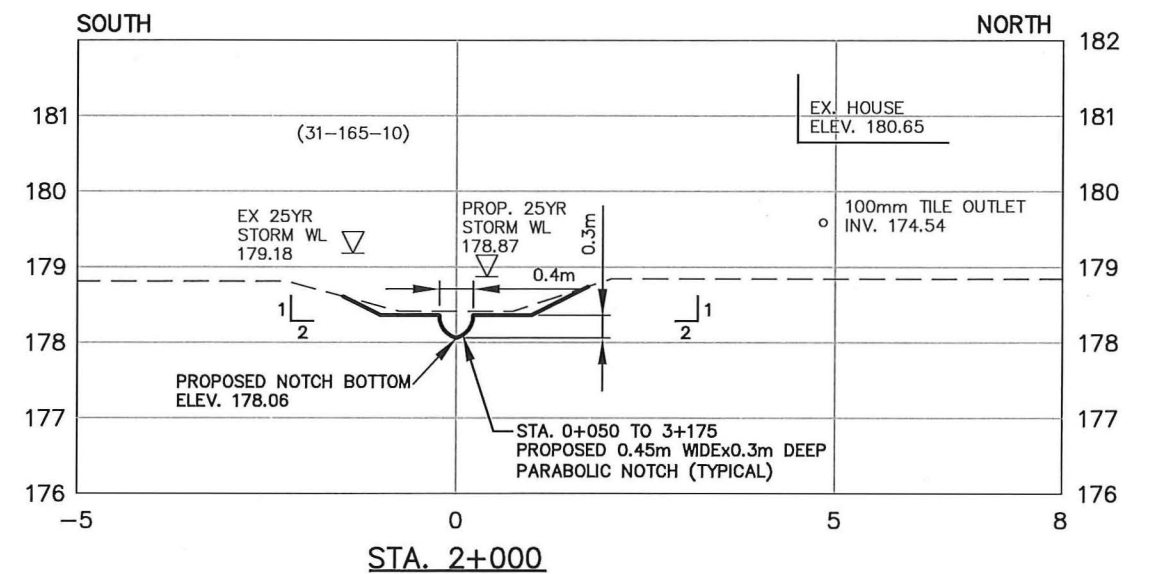
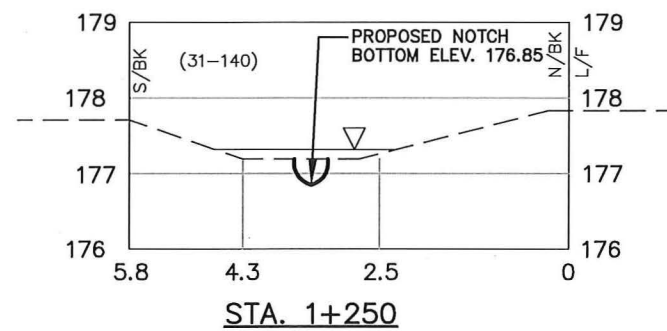
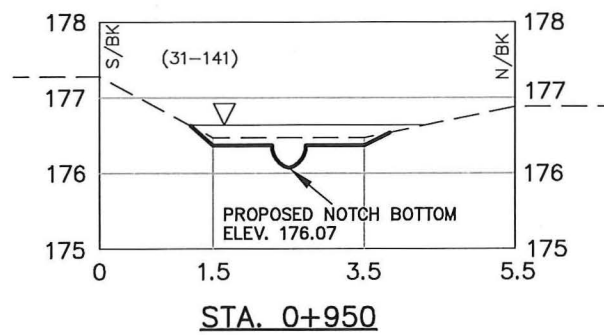
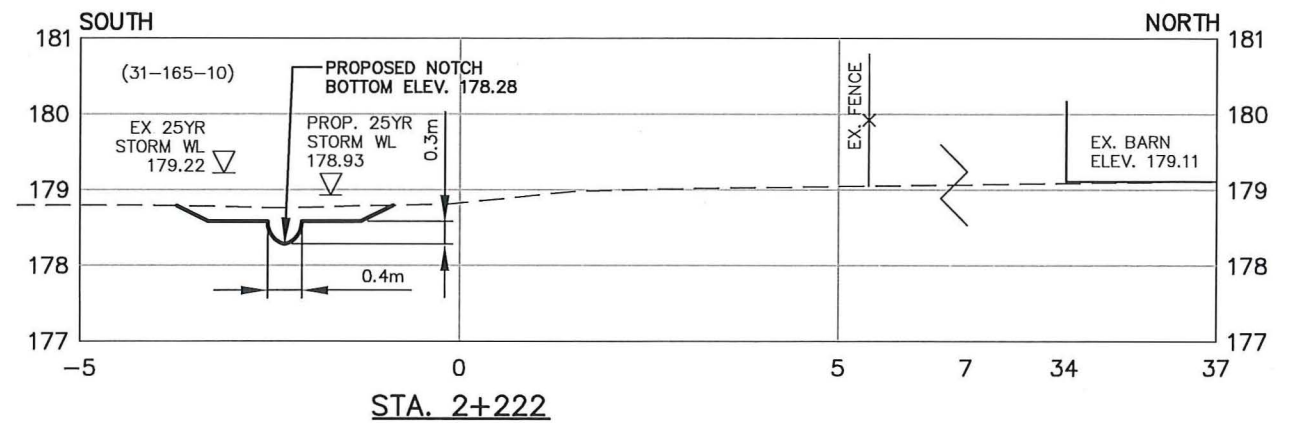
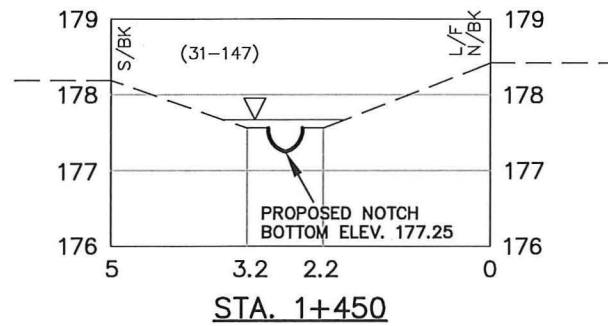
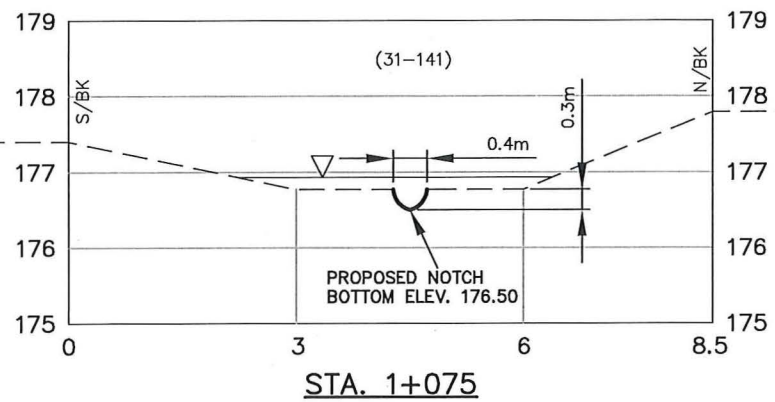

DESIGNED BY: N.W.M.		SCALE 1 : 2m
CHECKED BY: N.W.M.		(SCALE 1 : 100) HORZ.
DRAWN BY: N.M.B.		(SCALE 1 : 100) VERT.
CHECKED BY: N.W.M.		(ON 11"x17")
FIELD BOOK: 02-210		

SCHIHLE DRAIN
 REGION OF NIAGARA TOWN OF FORT ERIE
 CITY OF PORT COLBORNE

CROSS SECTIONS	MAR. 28, 2019
	REVISED: JOB NUMBER: 02-210 DRAWING 9 OF 12

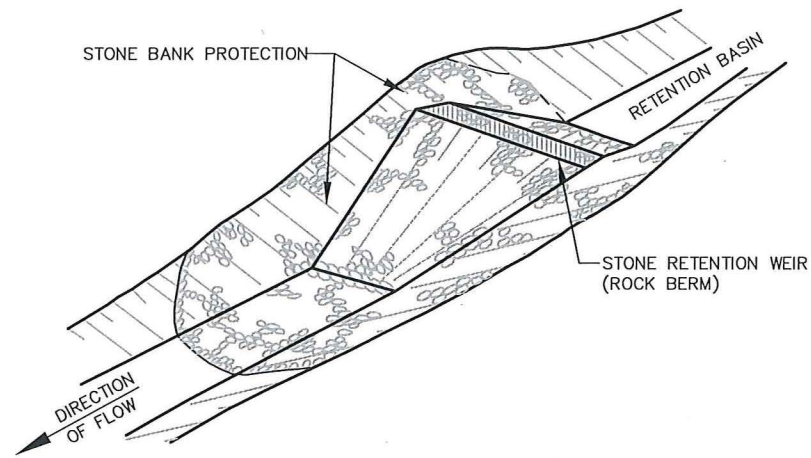
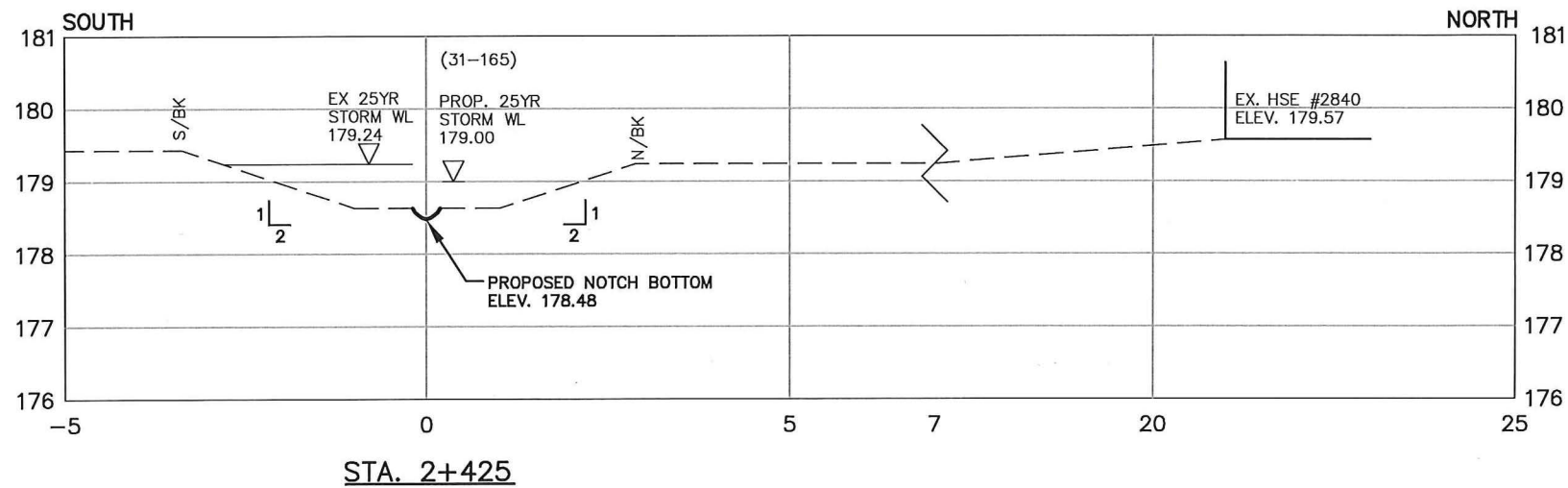
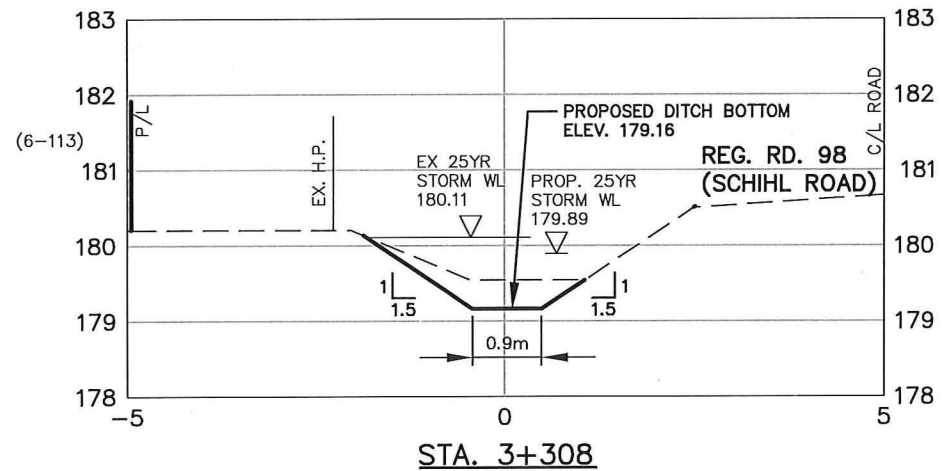
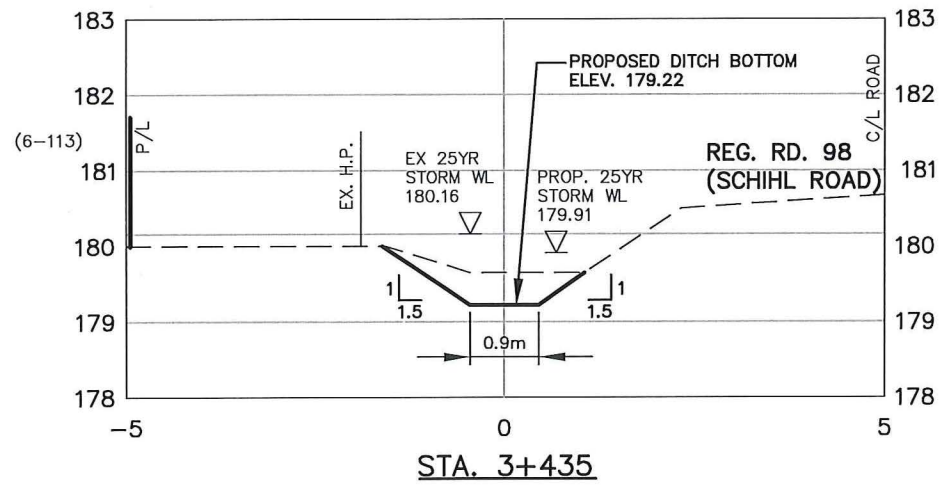

"h" & "w" ARE SPECIFIED IN PROJECTS "EXTENT OF WORK"

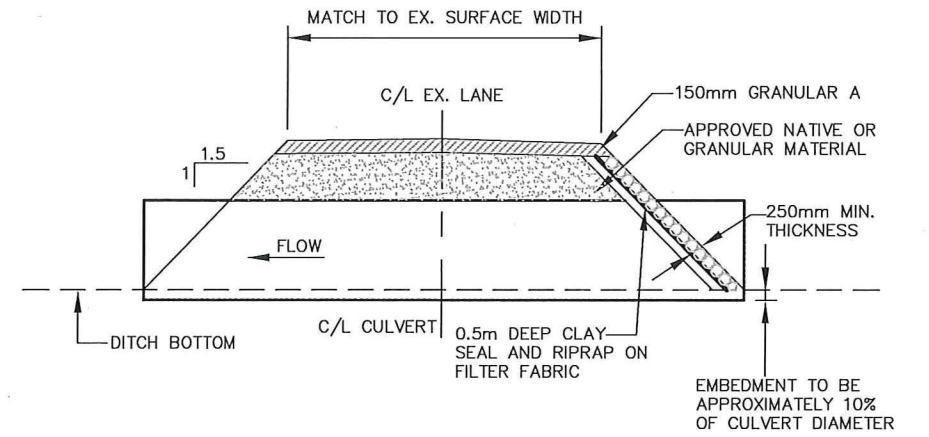

NOTES:

1. ALL GRANULAR MATERIAL TO BE COMPACTED TO 98% SPMD WITH A MECHANICAL VIBRATORY COMPACTOR
2. CLAY SEAL AND RIPRAP TO EXTEND 1.0m EACH SIDE OF CULVERT
3. NO ROCKS OR AGGREGATES WITH A DIAMETER GREATER THAN 100mm SHALL BE PLACED WITHIN 200mm OF THE PIPE

STANDARD DRAWINGS

N.T.S.

DESIGNED BY: N.W.M.		SCALE
CHECKED BY: N.W.M.		0 1 2m
DRAWN BY: C.J.M.		(SCALE 1:100)
CHECKED BY: N.W.M.		0 2m
FIELD BOOK: 02-210		(SCALE 1:100)
		VERT.
		(ON 11"x17")

SCHIHL DRAIN
 REGION OF NIAGARA TOWN OF FORT ERIE
 CITY OF PORT COLBORNE

CROSS SECTIONS CONTINUED AND STANDARD DRAWINGS
 MAR. 28, 2019

REVISED:
 JOB NUMBER: 02-210
 DRAWING
 K. SMART ASSOCIATES LIMITED
 CONSULTING ENGINEERS AND PLANNERS
 KITCHENER SUDBURY

10 OF 12

300) SPECIAL PROVISIONS

300.1) SPECIFIC NOTES

A description of the Drain for construction and future maintenance is as follows:

R. Singleton (Roll No. 31-086) / J. Robertson & S. Cavey (Roll No. 31-087) / D. Merritt (Roll No. 31-088 & 31-089) / R. Charron (Roll No. 31-094)

- 0+000 to 0+050 - No work required. This portion was cleaned out (excavated) during St. John's Marsh Drain 2016 construction.
- For future maintenance, ditch to be 2.5m wide bottom, 2:1 side slopes and spoil to be levelled on south side
- 0+050 to 0+485 - Power brushing 10m width on the south side of the drain
- 0+050 to 0+754 - 704m of ditch cleanout, 2.5m wide bottom, 2:1 side slopes. Level spoil on the south side of drain including incidental brushing Sta. 0+485 to 0+754
- Seeding of ditch banks (5m sides)
- 0+752 - Construct permanent rock sediment trap with 10m² of riprap

Point Abino Road (Town of Fort Erie)

- 0+754 to 0+758 - 4m of ditch cleanout, 2.5m wide bottom, 2:1 side slopes. Level spoil to south/east on Roll No. 31-094
- Seeding of ditch banks (5m sides)
- 0+758 to 0+776 - No work required. Existing twin (2) 18m lengths of 1150mm high x 1450mm wide elliptical CSP arch culverts to be incorporated
- 0+776 to 0+777 - 1m of ditch cleanout, 2m wide bottom, 2:1 side slopes. Level spoil to the south/west side on Roll No. 31-141

H. Van Der Meer (House No. 2909) (Roll No. 31-141) / Willoyd Ltd. (Roll No. 31-140)

- 0+777 to 1+050 - 273m of ditch cleanout/excavation, 2m wide bottom, 2:1 side slopes. Level spoil on south side including incidental brushing on the south side of the drain
- Seeding of ditch banks (5m sides)
- 1+050 to 1+327 - 277m of ditch cleanout/excavation, 2m wide bottom, 2:1 side slopes. Level spoil on the south side
- Seeding of ditch bank (4m sides)
- 1+100 to 1+327 - Power brushing in ditch and 10m on the south side of the drain
- 1+095 - Clean through existing 3 – 5.5m lengths of 900mm dia. CSP culverts on Roll No. 31-141. Existing culverts to be incorporated

W. Yuan & G. Li (Roll No. 31-146) / C. Stackwood (Roll No. 31-147) / R. & A. Swinson (Roll No. 31-148) / Willoyd Ltd. (Roll No. 31-140) / C.P.R.-Caso (Roll No. 31-996) / Willoyd Ltd. (Roll No. 31-140)

- 1+327 to 1+668 - Power brushing in the ditch
- 1+327 to 1+743 - 416m of ditch cleanout/excavation, 2m wide bottom, 2:1 side slopes. Level spoil on the north side.
- Seeding of ditch banks (4m sides)
- 1+668 to 1+743 - Power brushing in ditch and 10m on the north side of the drain
- 1+743 to 1+760 - Clean through the existing 17m length of 1200mm dia. steel smooth wall pipe, with headwall at the upstream end, railway culvert. Level spoil on Roll No. 31-140
- 1+760 to 1+884 - Power brushing in ditch and 5m on the north side of the drain
- 125m of ditch cleanout/excavation, 2m wide bottom, 2:1 side slopes
- 1+880 - Construct permanent rock sediment trap with 10m² of riprap

Burger Road (Town of Fort Erie)

- 1+884 to 1+890 - 6m of ditch cleanout/excavation, 2m wide bottom, 2:1 side slopes. Level spoil on Roll No. 31-140
- 1+890 to 1+899 - Existing 9m length of the 1.85m wide x 0.75m high concrete culvert (no concrete bottom) to remain. No work required. Pipe to be installed as per detail on Drawing 12
- 1+889 to 1+899 - Install 10m of 750mm dia. HDPE pipe beside existing culvert across the road by open cut including restoration
- 1+899 to 1+904 - 5m of ditch cleanout/excavation, 2m wide bottom, 2:1 side slopes. Level spoil on Roll No. 31-165-10

D. & T. Brewster (House No. 2845) (Roll No. 31-165-10) / W. & K. Hawkins (House No. 2840) (Roll No. 31-165)

- 1+904 to 2+317± - Power brushing in ditch and 10m on the south side
- 1+904 to 2+468 - 564m of ditch cleanout/excavation, 2m wide bottom, 2:1 side slopes. Level spoil on the south side.
- Seeding of ditch banks (4m sides)

- 2+055± - Construct low flow crossing consisting of twin (2) 4m lengths of 600mm dia. HDPE pipes and 40m² of riprap.
- 2+410 to 2+418 - Caution: Avoid damage (do not disturb) existing swimming pool to the south

Holloway Bay Road (Town of Fort Erie / City of Port Colborne)

- 2+468 to 2+473 - 5m of ditch cleanout/excavation, 2m wide bottom, 2:1 side slopes. Level spoil on Roll No. 31-165
- 2+473 to 2+483 - Cleanout through the existing 10m length of 1.85m wide by 0.65m high concrete culvert with headwalls. No concrete bottom.
- 2+483 to 2+488 - 5m of ditch cleanout/excavation, 1.5m wide bottom, 2:1 side slopes. Level spoil on Roll No. 6-113

776542 Ontario Ltd. (Roll No. 6-113)

- 2+488 to 2+625 - Power brushing in ditch and 10m on the south side of the drain
- 137m of ditch cleanout/excavation, 1.5m wide bottom, 2:1 side slopes. Level spoil on the south side.
- Seeding of ditch banks (4m sides)
- 2+625 to 3+010 - Power brushing 10m width and in the ditch
- 385m of debris removal
- 2+831 - Existing 1.5m wide footbridge (ATV crossing) to be removed and replaced by the landowner
- 3+010 to 3+175 - 165m of ditch cleanout/excavation, 1.5m wide bottom, 2:1 side slopes. Level spoil on the south side.
- Seeding of ditch banks (4m sides)
- 3+170 - Construct permanent rock sediment trap with 10m² of riprap

Regional Road 98 (Schihl Road) (Region of Niagara) / 776542 Ontario Ltd. (Roll No. 6-113)

- 3+175 to 3+490 - 315m of ditch cleanout/excavation, 0.9m wide bottom, 1.5:1 side slopes. Level spoil on the east side on Roll No. 6-113.
- Seeding of ditch banks (2m sides)

Regional Road 98 (Schihl Road) (Region of Niagara) / 776542 Ontario Ltd. (Roll No. 6-121) / Regional Road 98 (Forkes Road) (Region of Niagara)

- 3+490 to 3+504 - Remove and dispose of existing culvert and install 14m lengths of 750mm and 900mm dia. PPE pipes across the road by open cut. Pipes to be installed as per detail on Drawing 12. Place 5m² of riprap at ends (10m² riprap total). Use "Sanitite HP" PPE High-Performance Polypropylene from ADS or equivalent for the pipe with 320 kN/m² or greater stiffness fabricated per AASHTO M330, with bell and spigot connections. Taper ditch at downstream and upstream ends
- 3+504 to 3+525 - Excavate 21m of the ditch, 0.9m wide bottom, 1.5:1 side slopes. Level spoil on the north side on Roll No. 6-121
- Seeding of ditch banks (2m sides)
- 3+525 to 3+537 - Remove and dispose of existing culvert and install 12m lengths of 750mm and 900mm dia. PPE pipes across the road by open cut. Pipes to be installed as per detail on Drawing 12. Place 5m² of riprap at ends (10m² riprap total). Use "Sanitite HP" PPE High-Performance Polypropylene from ADS or equivalent for the pipe with 320 kN/m² or greater stiffness fabricated per AASHTO M330, with bell and spigot connections.
- Taper 5m of the ditch at downstream and upstream ends

300.2) GENERAL NOTES

300.2.1 Working Area

For work on the open ditch, the average width is to be 10m on private lands. Refer to Standard Specification 400.4 for exceptions.

300.2.2 Access – Standard Specification 400.5

The Contractor shall have access to the drain along the routes if any, shown on the plan. The access routes shall be along existing laneways or paths or where none exist, along a 6m wide (maximum) path. All specifications governing fences, livestock and crops during drain construction shall apply to access routes except where superseded by notes on the drawings. No other access routes shall be used unless first approved by the Engineer and affected landowners. The Contractor shall also contact each owner prior to using designated accesses. The landowner information will be supplied with the tender documents.

Telephone numbers for contact are:

- 31-086 R. Singleton
- 31-087 J. Robertson & S. Cavey (Available at time of tender)

- 31-088, 31-089 D. Merritt
- 31-094 R. Charron
- 31-140, 31-141 Willoyd Ltd. (H. Van Der Meer)
- 31-165 W. & K. Hawkins
- 31-165-10 D. & T. Brewster
- 31-996 C.P.R.-Caso
- 6-075, 6-113, 6-121 776542 Ontario Ltd.
- Engineer (Neal Morris, P. Eng.) 519-748-1199 ext. 240
- Town of Fort Erie (Dave Maiden, Drainage Superintendent) 905-871-1600 ext. 2405
- City of Port Colborne (Alana Vander Veen, Drainage Superintendent) 905-835-2801 ext. 2192900 ext 291
- Region of Niagara (Derek McGaghey) 905-980-6000 ext. 3412
- One Call Centre 1-800-400-2055

300.2.3 Ditch Work Required

All construction on this project must use laser grade control for open work. Failure to do such may require forfeiture of the contract including tender deposit and payment for any work done.

a) General Note for Ditch Work on this Project

In all areas, the side of the drain for levelling spoil is to be the working side. Power brushing materials are preferred. Where materials are cut by chainsaw or excavated by a backhoe, materials are to be left in piles for the landowner to dispose of. Where bush is within 10m of the channel, such materials are to be pushed and windrowed in with or adjacent to the bush areas. All incidental brushing along the drain is to be included as part of the ditch work unless it is separately noted in the Specific Notes. All new ditch banks are to be seeded.

b) General re Open Drain Work

The open drains to be constructed will have cross-sectional dimensions as specified by the profiles and the Typical Sections on the drawings. Ditch bottom elevations are to be as shown on the profile drawings. Also, minimum bottom widths and bank slopes are shown by the typical sections and by the profile drawings. All spoil is to be levelled adjacent to the drain, and all banks where disturbed, are to be seeded the same day as excavation unless when requested otherwise. Standard Specification 410 applies for ditch work. Do not over-excavate any channel except if noted, do not unnecessarily disturb banks, and minimize bottom disturbance during root removal.

During future maintenance, all excavated materials are to be levelled on adjacent properties with the exception that any removed rock be hauled away.

300.2.4 Soil Conditions

The Region of Niagara soils map for this area indicates that the soils adjacent to this drain are lacustrine heavy clay and silty clay over clay loam till. These soils should not present significant construction difficulty but pockets of poor soil conditions may be experienced, especially if groundwater levels are high at the time of construction.

If pockets of poor soils conditions are encountered, the contingency price from the form of the tender will be paid by the linear meter upon the engineer's approval. This contingency price is based on increased costs relating to the contractors time and materials.

300.2.5 Native Seed (Seeding Mixture)

Use Sassafras Farm's wetland sites mixture or approved equal. Seed mixture is to be applied at a rate of 3 kg per hectare, and is to contain:

Botanical Name	Common Name	%
(<i>Carex vulpinoidea</i>)	Fox Sedge	20
(<i>Juncus effuses</i>)	Soft Rush	5
(<i>Carex lupulina</i>)	Hop Sedge	4
(<i>Elymus Riparius</i>)	River Bank Wild Rye	22
(<i>Elymus Canadensis</i>)	Canada Wild Rye	25
(<i>Mimulus ringens</i>)	Monkey Flower	1
(<i>Verbena hastate</i>)	Blue Vervain	2
(<i>Aster novae-angliae</i>)	New England Aster	3
(<i>Carex stipata</i>)	Awl Sedge	3
(<i>Eupatorium fistulosum</i>)	Joe Pye Weed	1
(<i>Eupatorium perfoliatum</i>)	Boneset	1
(<i>Scirpus cyperinus</i>)	Wool Grass	7
(<i>Asclepias incarnate</i>)	Swamp Milkweed	1
(<i>Solidago patula</i>)	Rough Leaved Goldenrod	5

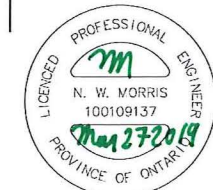

SCHIHl DRAIN
TOWN OF FORT ERIE and CITY OF PORT COLBORNE
 Region of Niagara
 File No. 02-210 March 28, 2019
 Drawing 11 of 12

ASPHALT THICKNESS TO BE MINIMUM 90mm (COMPACTED) HOT MIX ASPHALT (40mm SURFACE COURSE PLUS 50mm BASE COURSE)
 150mm GRAN. A AND 450mm GRAN. B GRANULAR COMPACTION TO 100% SPMD FOR PAVED SURFACE, IF PRESENT.
 MINIMUM GRANULAR THICKNESS OF 150mm GRAN. A AND 450mm GRAN. B GRANULAR COMPACTION TO 98% SPMD FOR GRAVEL SURFACE

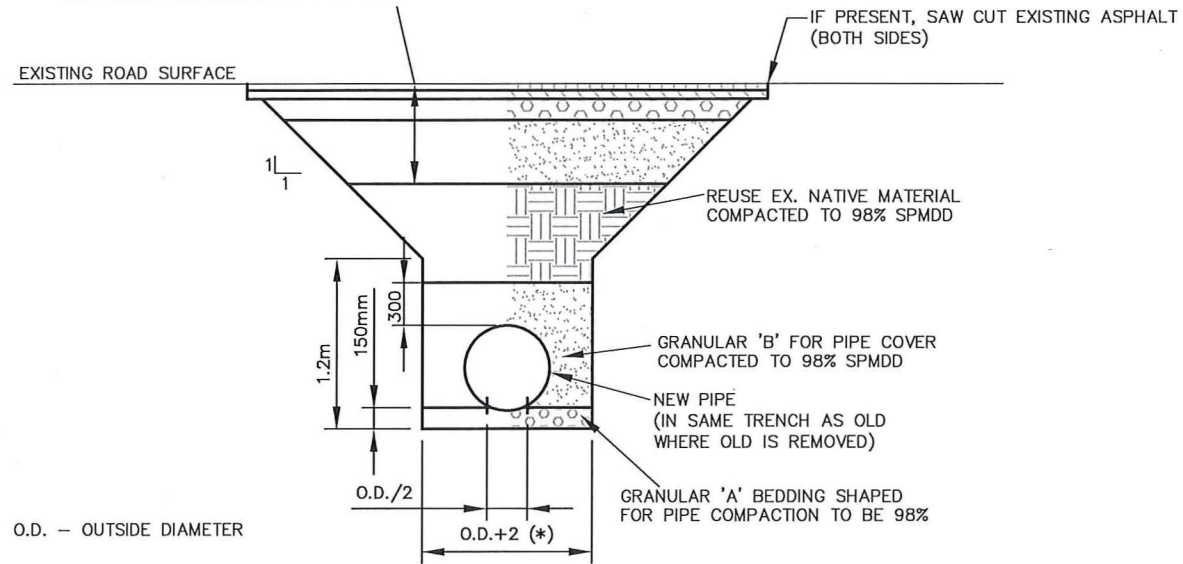

TRENCH DETAIL FOR ROAD CROSSING BY OPEN CUT
 (PAVED OR GRAVEL SURFACE)
 N.T.S.

NOTES:

- ALL WORK TO BE IN ACCORDANCE WITH OPSS AND OPSD
- * - MINIMUM TRENCH SIDEWALL CLEARANCE PER OPSD 802.010
 PIPE DIA. ≤ 900φ - 0.3m
 PIPE DIA. > 900φ - 0.5m
- THESE PADDING, BACKFILL AND COMPACTION REQUIREMENTS ALSO APPLY BEYOND THE SHOULDER AT A 1:1 SLOPE DOWN TO THE BOTTOM OF TRENCH EXCAVATION
- NEW FROST TAPER NOT REQUIRED UNLESS REQUESTED AT TIME OF CONSTRUCTION. BLEND INTO EXISTING TAPERS
- NEW FROST TAPERS IF REQUIRED ARE TO BE IN ACCORDANCE WITH OPSD 803.03 AND ADDITIONAL PAYMENT WILL BE ALLOWED.
- ALL SURPLUS EXCAVATED MATERIAL TO BE HAULED AWAY
- CONTRACTOR TO PERFORM ROAD RECONSTRUCTION IN ACCORDANCE WITH OPSS 310
- CONSTRUCTION SPECIFICATION FOR HOT MIX ASPHALT INCLUDING RELATED SPECIFICATIONS OPSS 1003 AND OPSS 1150.
- IN INITIAL CONSTRUCTION SEASON ALL LIFTS OF ASPHALT SHALL BE PLACED IF CONDITIONS ARE SUITABLE. IF CONDITIONS ARE POOR, TEMPORARY ASPHALT MAY BE REQUIRED UNTIL FOLLOWING CONSTRUCTION YEAR.
- OPEN CUT INSTALLATION METHOD WILL RESULT IN TEMPORARY ROAD CLOSURE AND DETOUR. TRAFFIC CONTROL REQUIRED.
- ALL UTILITIES MUST BE LOCATED BY THE CONTRACTOR
- REFER TO GENERAL AND/OR SPECIAL PROVISION NOTES FOR CONFIRMATION OF PIPE TYPE, SIZE AND LENGTH PLUS TYPE OF END TREATMENT
- HOT MIX ASPHALT SHALL BE IN ACCORDANCE TO THE ROAD AUTHORITIES MIX DESIGN

MUNICIPAL ROAD CROSSING

ASPHALT THICKNESS TO BE MINIMUM 150mm (COMPACTED) HOT MIX ASPHALT (50mm HL3HS SURFACE COURSE IN ONE LIFT, PLUS 100mm HL8HS BASE COURSE IN TWO LIFTS OF 50mm), 150mm GRAN. A AND 450mm GRAN. B GRANULAR COMPACTION TO 100% SPMD FOR PAVED SURFACE, IF PRESENT.
 MINIMUM GRANULAR THICKNESS OF 150mm GRAN. A AND 450mm GRAN. B GRANULAR COMPACTION TO 98% SPMD FOR GRAVEL SURFACE

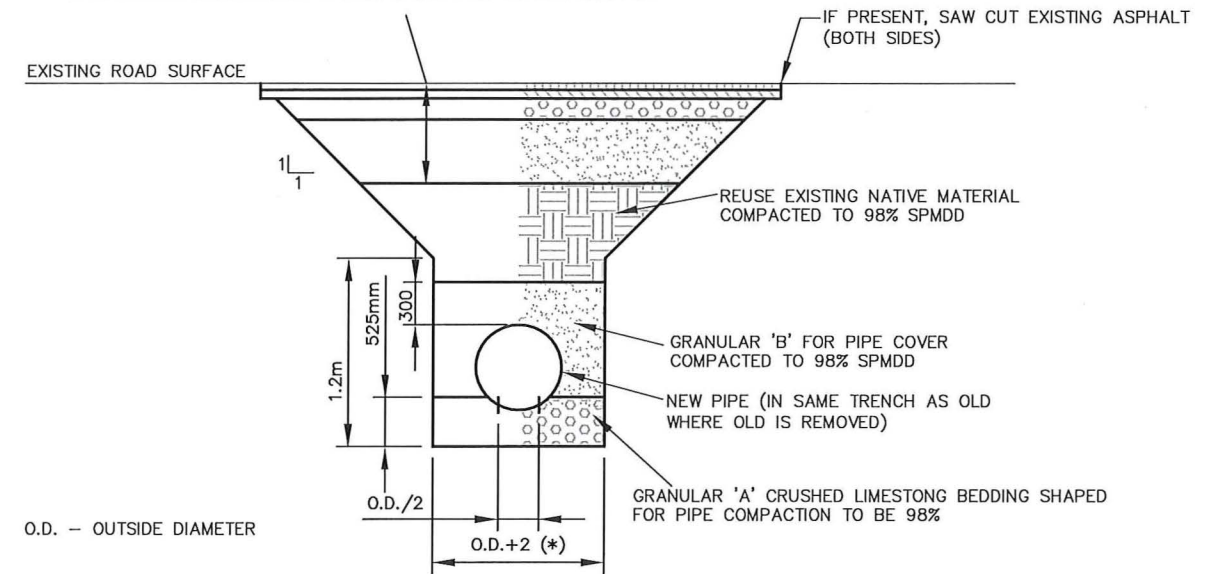

TRENCH DETAIL FOR ROAD CROSSING BY OPEN CUT
 (PAVED OR GRAVEL SURFACE)
 N.T.S.

NOTES:

- ALL WORK TO BE IN ACCORDANCE WITH OPSS AND OPSD
- * - MINIMUM TRENCH SIDEWALL CLEARANCE PER OPSD 802.010
 PIPE DIA. ≤ 900φ - 0.3m
 PIPE DIA. > 900φ - 0.5m
- THESE PADDING, BACKFILL AND COMPACTION REQUIREMENTS ALSO APPLY BEYOND THE SHOULDER AT A 1:1 SLOPE DOWN TO THE BOTTOM OF TRENCH EXCAVATION
- NEW FROST TAPER NOT REQUIRED UNLESS REQUESTED AT TIME OF CONSTRUCTION. BLEND INTO EXISTING TAPERS
- NEW FROST TAPERS IF REQUIRED ARE TO BE IN ACCORDANCE WITH OPSD 803.03 AND ADDITIONAL PAYMENT WILL BE ALLOWED.
- ALL SURPLUS EXCAVATED MATERIAL TO BE HAULED AWAY
- CONTRACTOR TO PERFORM ROAD RECONSTRUCTION IN ACCORDANCE WITH OPSS 310
- CONSTRUCTION SPECIFICATION FOR HOT MIX ASPHALT INCLUDING RELATED SPECIFICATIONS OPSS 1003 AND OPSS 1150.
- IN INITIAL CONSTRUCTION SEASON ALL LIFTS OF ASPHALT SHALL BE PLACED IF CONDITIONS ARE SUITABLE. IF CONDITIONS ARE POOR, TEMPORARY ASPHALT MAY BE REQUIRED UNTIL FOLLOWING CONSTRUCTION YEAR.
- OPEN CUT INSTALLATION METHOD WILL RESULT IN TEMPORARY ROAD CLOSURE AND DETOUR. TRAFFIC CONTROL REQUIRED.
- ALL UTILITIES MUST BE LOCATED BY THE CONTRACTOR
- REFER TO GENERAL AND/OR SPECIAL PROVISION NOTES FOR CONFIRMATION OF PIPE TYPE, SIZE AND LENGTH PLUS TYPE OF END TREATMENT
- HOT MIX ASPHALT SHALL BE IN ACCORDANCE TO THE ROAD AUTHORITIES MIX DESIGN

REGION OF NIAGARA ROAD CROSSINGS

DESIGNED BY: N.W.M.			N.T.S.	
CHECKED BY: N.W.M.				
DRAWN BY: N.M.B.				
CHECKED BY: N.W.M.				
FIELD BOOK: 02-210				
SCHIDL DRAIN REGION OF NIAGARA TOWN OF FORT ERIE CITY OF PORT COLBORNE			MAR. 28, 2019	
MUNICIPAL ROAD AND REGION OF NIAGARA ROAD CROSSINGS			REVISED: JOB NUMBER: 02-210 DRAWING: 12 OF 12	

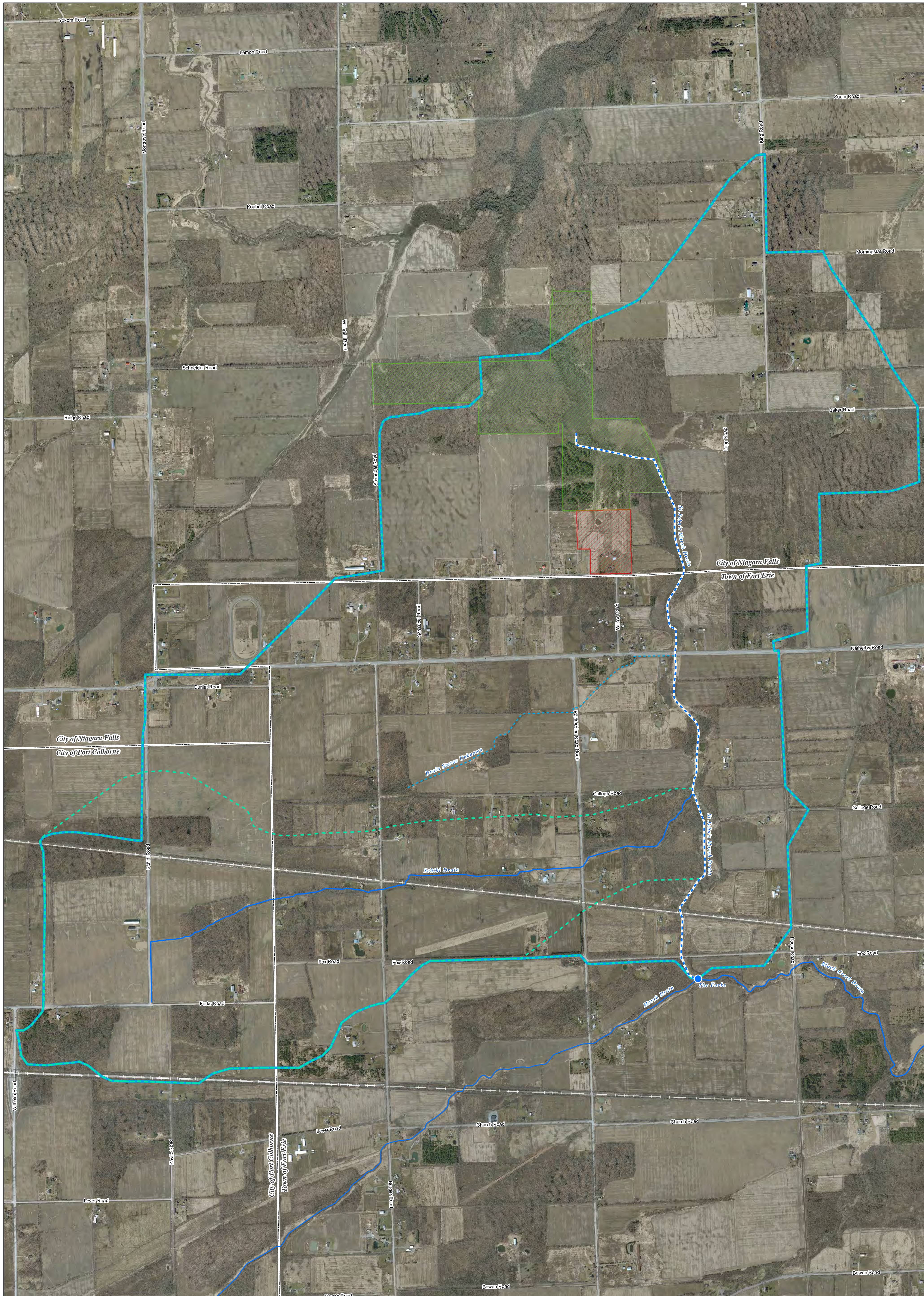

- St John's Marsh Drain Watershed
- Schihl Drain Sub Watershed
- 5981 Willow Rd
- NPCA Parcel
- St John's Marsh Drain
- Municipal Drain
- Status Unknown - Drain
- Municipal Boundary

St John's Marsh Drain

1:9,000

0 0.125 0.25 0.5 0.75 1 Km

PORT COLBORNE



City of Port Colborne
Regular Meeting of Council 16-19
Monday, June 10, 2019
following Committee of the Whole Meeting
Council Chambers, 3rd Floor, 66 Charlotte Street

Addendum

Additional Item(s) for Consideration:

Notes	Item	Description / Recommendation
WCS MB EB	18	<p><u>Engineering and Operations Department, Engineering Division, Report 2019-81, Subject Schihl Municipal Drains</u></p> <p>That Engineering and Operations Department, Engineering Division Report 2019-81 with respect to the Schihl Municipal Drain, be received for information.</p> <p>That staff be directed to advance the Schihl Municipal Drain Engineer's Report to that of the Meeting to Consider, as per Section 41, Chapter D.17 of the <i>Drainage Act R.S.O. 1990</i>.</p>
RB GB FD		
AD DK HW		

This page left intentionally blank